

Application

1. Water circulating of ponds
2. Lawn sprinkling
3. Garden watering and car washing
4. Dewatering the basement
5. Trenches
6. Excavation and construction sites

Features

1. Motor with built-in temperature protection.
2. Sturdy composite construction and glass-filled polypropylene housing resist corrosion.
3. Efficient cooling design keeps motor running cooler for longer life.
4. Compact size and light weight fit into out of the way places.
5. The "R" type available to used in sea fish breeding.
6. The "C" type equipped level regulator.
7. The "F" type equipped float ball level switch.
8. The "D" type low suction capability up to 0.12".

Specifications

1. Power supply: single-phase 60 Hz
2. Power: 100W to 400W
3. Insulation class: B
4. Protection: IP68
5. Length of cable: 13 ft or 16 ft
6. Delivery: up to 68.6 GPM
7. Head: up to 32.8 ft

Suitable liquids

1. Suitable to pumping clean, non-aggressive water and slightly dirty (grey) wastewater.
2. When pumping salt water such as sea fish bleeding, please select PW100AR and PW400AR.
3. Temperature of pumped liquid: +39.2°F to +95°F

Hydraulic performance curve

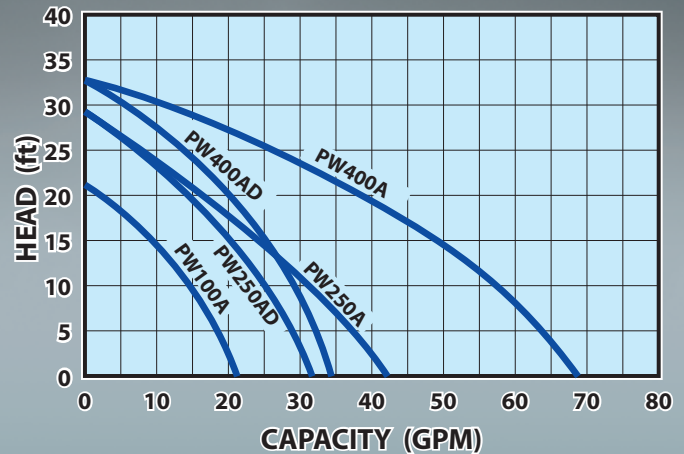

PW100AC

PW100AR

PW100A



PW250AF

PW400A

PW400AD



Level regulator

PW100AC / PW100ARC

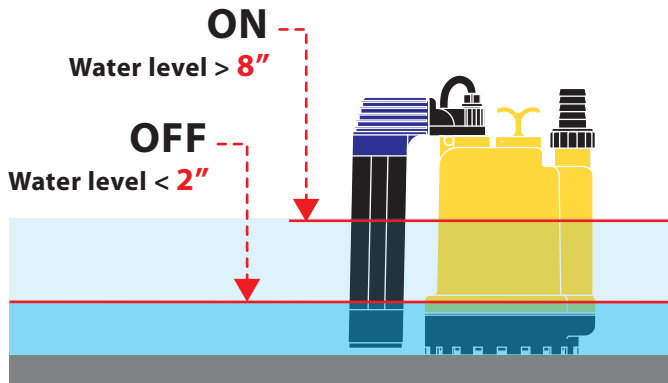

Float ball level switch

PW100AF / PW100ARF / PW250AF

PW400AF / PW400ARF

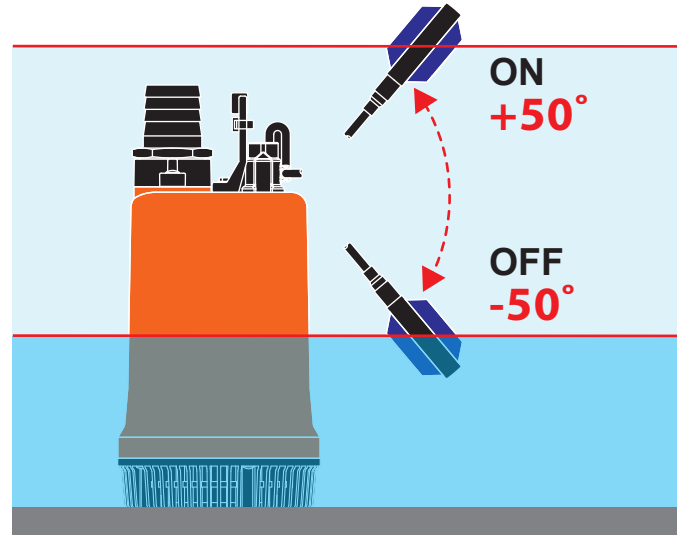

Specifications

Type	Outlet Diameter (in.)	Output (W)	Volt (V)	Amp's (A)	Maximum		Dimensions L x W x H (in)	Cable Wire C x mm ² x ft	N.W. (lbs)	G.W. (lbs)	
					Head (ft)	Capacity (GPM)					
PW100A	1"	100	115 or 230	2.0 or 1.0	21.3	21.1	6.10 x 5.51 x 9.49	3 x 0.75 x 13	9.0	10.4	72
PW250A	1½"	250	115 or 230	4.0 or 2.0	29.5	42.2	6.46 x 6.46 x 13.78	3 x 1.25 x 16	11.2	12.1	48
PW400A	2"	400	115 or 230	7.0 or 3.5	32.8	68.6	7.20 x 7.20 x 15.04	3 x 1.25 x 16	17.4	18.5	50

Sea water pump

PW100AR	1"	100	115 or 230	2.0 or 1.0	21.3	21.1	6.10 x 5.51 x 9.49	3 x 0.75 x 13	9.0	10.4	72
PW400AR	2"	400	115 or 230	7.0 or 3.5	32.8	68.6	7.20 x 7.20 x 15.04	3 x 1.25 x 16	17.4	18.5	50

Pump with level regulator

PW100AC PW100ARC	1"	100	115 or 230	2.0 or 1.0	21.3	21.1	8.66 x 5.51 x 9.49	3 x 0.75 x 13	10.1	11.2	48
---------------------	----	-----	------------	------------	------	------	--------------------	---------------	------	------	----

Pump with float ball level switch

PW100AF PW100ARF	1"	100	115 or 230	2.0 or 1.0	21.3	21.1	6.10 x 5.51 x 9.49	3 x 0.75 x 13	9.5	10.8	48
PW250AF	1½"	250	115 or 230	4.0 or 2.0	29.5	42.2	6.46 x 6.46 x 13.78	3 x 1.25 x 16	11.7	12.6	48
PW400AF PW400ARF	2"	400	115 or 230	7.0 or 3.5	32.8	68.6	7.20 x 7.20 x 15.04	3 x 1.25 x 16	17.9	18.7	50

Low suction pump (Drainage to 0.12" from floor)

PW250AD	1½"	250	115 or 230	4.0 or 2.0	29.5	31.7	6.46 x 6.46 x 13.78	3 x 1.25 x 16	12.3	13.2	48
PW400AD	2"	400	115 or 230	7.0 or 3.5	32.8	34.3	7.20 x 7.20 x 15.04	3 x 1.25 x 16	18.5	19.4	50