



**WALRUS**  
PUMP

*HQ Series*

# Instruction Manual

## Electronic Control Pump

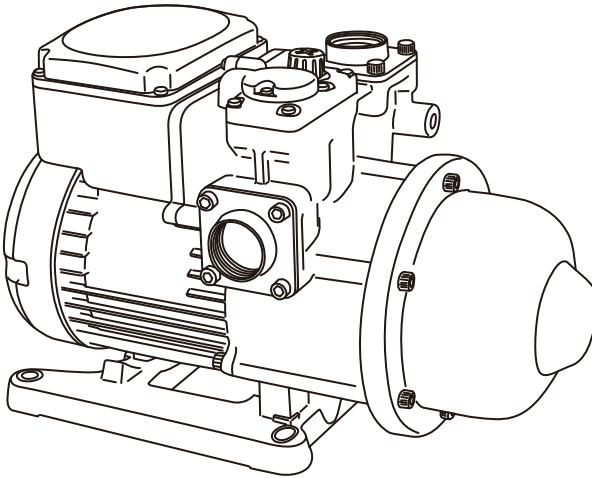

Model : HQ200 / HQ400 / HQ800 / HQ800H

To ensure safe and proper use, please read this instruction before operation.

ISO 9001 Certified

Walrus America Inc.





# EC Declaration of Conformity

Manufacturer:

Walrus Pump Co., Ltd.

Address:

No.83-14, Dapiantou, Sanzhi Dist., New Taipei City 252, Taiwan

Declare that the machinery described:

Name : Water Pump

Model : HQ Series

Conform to the following directive:

2006/42/EC—Machinery directive

2014/35/EU—Low voltage directive

2014/30/EU—EMC (Electromagnetic compatibility) directive

Refer to the following standards:

EN ISO 12100:2010

EN ISO 13857:2008

EN 809:1998+A1:2009

EN 60335-1:2012

EN 60335-2-41:2003+A2:2012

EN 61000-6-2:2005

EN 61000-6-3:2007

R&D Department: Chen, Wei-Chu.

Director: *Chen, Wei-Chu.*

# HQ Series Instruction Manual

Please read all instructions carefully before installing your new systems, as failures caused by incorrect installation or operation are not covered by the warranty.

## I. Product

The HQ series are designed for the pumping of non-aggressive water, or water not containing solid particles.

## II. Operating conditions:

1. Ambient temp. : Max. +104°F (40°C)
2. Liquid temp. : +39°F(4°C) ~ +104°F(40°C)Max.
3. System pressure: Max. 120 PSI
4. Relative humidity: Max. 85%(RH)

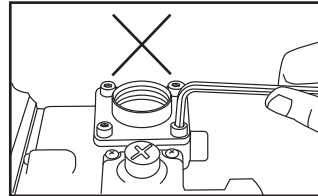

Fig. 1

## III. For new pump installation

1. The inlet and outlet flanges are tightened to the pump casing before shipment. For new pump installation, please do not remove the flanges.

( See Fig 1 ) Because of the use of self tapping screws, please use extra care when you have to remove the flanges for future maintenance.

2. Install union to inlet and outlet piping prior installing them to pump flanges( See Fig 2 ).
3. The pump foundation should be rigid enough to absorb any vibration from the motor, and the pump should be securely bolted to the foundation.
4. Please provide an adequate draining system to avoid damage in case of leakage, particularly when installed indoors. When it is installed outside, it should be covered by a weather-proof and well ventilated housing.
5. The pump and all piping must be protected from freezing. When the pump will be exposed to temperature less than 32°F (0°C), remove it to a heated area.

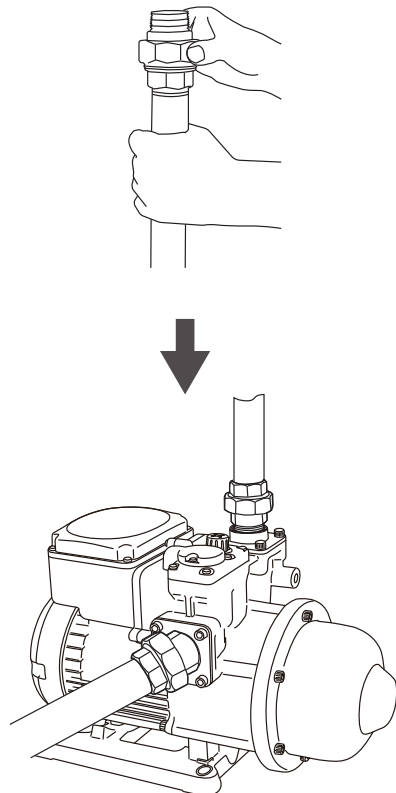

Fig. 2

6. Connect the suction pipe to the side and discharge pipe on the top.( See Fig 3 )

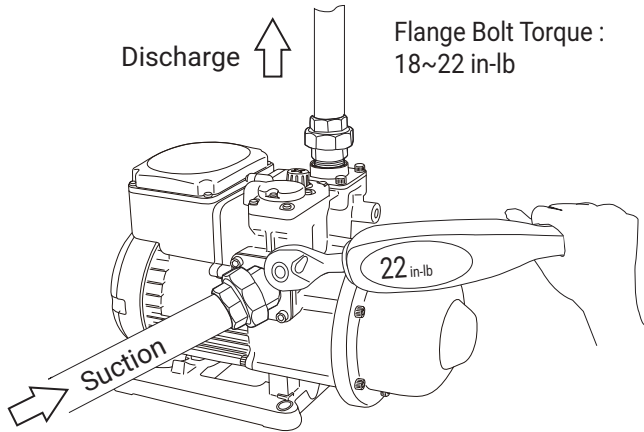

Fig. 3

7. When installed with a water heater, a check valve should be installed between pump (discharge) pipeline and water heater (suction) to avoid high-pressure steam backflow.
8. Regular maintenance requires you to open the prime cover in order to access the check valve.

DO NOT apply any bonded material (such as silicon, glue etc) to seal the chamber cover ( See Fig 4).

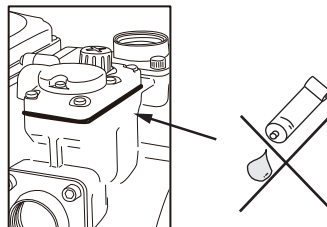

Fig. 4

#### IV. Piping

1. The suction line should be installed as short and straight as possible, with a minimum of bends. The internal diameter of the suction pipe must be equal to, or greater than the ports of the pump.
2. The connection between the suction line and pump must be airtight, and the suction pipe must be positioned so it has an downward slope to the pump (thus avoiding the formation of air pockets).
3. If it is likely the water supply may contain solid particles, such as leaves and sand, a filter should be installed on the suction line.
4. If hose is used as the suction pipe, it must be non-collapsible.
5. To minimize pressure drop, the discharge pipe should be at least the same size as the discharge port of the pump.
6. For long suction pipes or high suction lifts over 13 ft, the suction pipe should be of greater diameter than the suction port.
7. Ensure all connections are completely sealed using thread tape only.

## V. Connections to Water Source

### 1. Flooded Suction- from Well System

With gravity feed to the pump, there are no special adjustments to be made. See Fig. 5 below for recommended layout. Simply make necessary plumbing connections and apply power. The pump is ready to use.

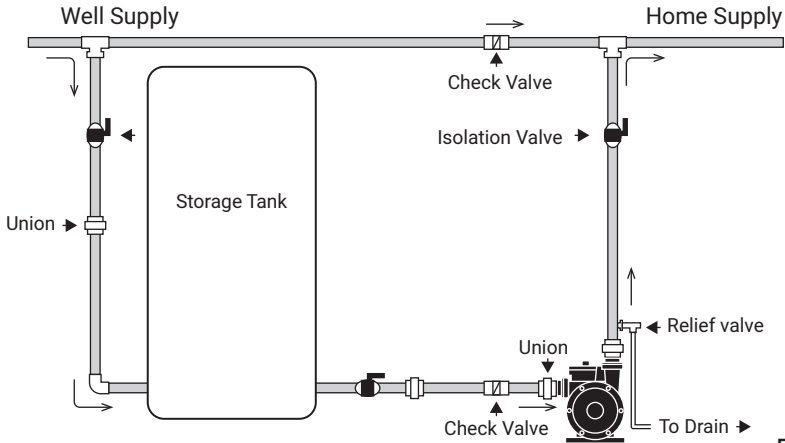

Fig. 5

### 2. Flooded Suction -from city water supply

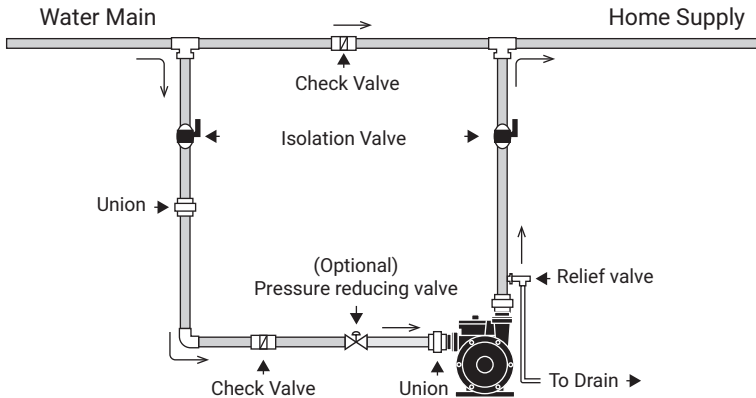

Fig. 6

Directly applied city pressure can exceed pump operating pressure and damage the pump. The max inlet pressure should not exceed 50 psi. Any greater incoming pressure it is required to install a pressure reducing valve on the suction side of the pump. In some areas where local codes restrict maximum home pressure, a pressure reducing valve is also required on suction to lower the inlet pressure. The chart below shows the applicable settings for the pressure reducing valve :

Local code limits for home pressure	Pressure reducing valve setting (psi)			
	HQ200	HQ400	HQ800	HQ800H
No limit	50	50	50	50
90 psi	50	45	40	25
80 psi	45	35	30	15

### 3. Suction Lift- below ground water sources

This connection does not require any adjustment. Whenever the installation position of the pump is higher than 3ft above the lowest water level, a foot valve must be installed on the end of suction pipe.

### VI.Warning

The pump is not designed for continuous operation under low discharge flows such as slow closing float valves, slow running taps. Under this application, please install an extra tank ( typically 2-3 gallon ) to avoid “cycling”. (Fig 7)

Please set the tank pressure same as pump pressure tank pressure. Leaking discharge line and leaking taps will damage the unit by causing the pump to repeatedly start and stop.

Note: Optional external water pressure tank can be used to decrease the on/off cycle rate of the pump system, which can extend the life of the pump.

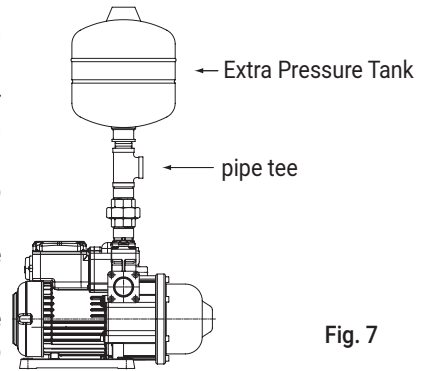

Fig. 7

### VII. Electrical connection



This mark located outside the connection box is a warning for an electrical hazard.

1. Ensure the mains voltage is the same as the value shown on the motor plate and that the pump is safely connected to ground/earth.

### VIII. Wiring diagram

#### WARNING:

Risk of electric shock - This pump has not been investigated for use in swimming pool or marine areas.

To reduce the risk of electric shock, connect only to a properly grounded, grounding-type receptacle.

Before operation, please ensure the voltage is correct and the circuit breaker and grounding connectors are all connected in accordance with local regulations.

Single-phase power supply

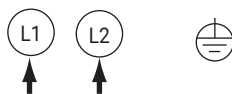

Input power

Grounding

Fig. 8

## IX. Starting

1. Before starting, the pump must be primed. For installation with no inlet pressure, please follow the procedure as shown in Fig 9.

a. Remove the filling plug

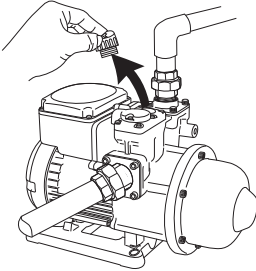

b. Fill water in chamber

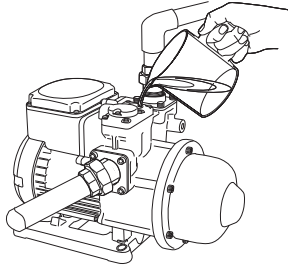

c. Replace the filling plug

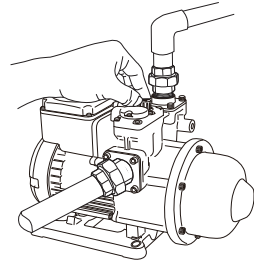

Fig. 9

2. For installation with inlet pressure, remove the priming plug and allow the water to flow into the priming chamber until all air is expelled.

3. The priming procedure should be repeated until all air is expelled and the pump delivers a full stream of water without air bubbles.

4. The pump must always be checked for prime if not used for a prolonged period. It is imperative to fill the pump with liquid before operation as dry running causes irreparable damage to the mechanical seal.

## X. Precautions

1. The pump should be shut down and the trouble corrected if the pump is running at speed and found to have any of the following problems:

- No liquid discharged - Not enough liquid discharged
- Excessive vibration - Motor runs hot

2. Do not allow the pump to continually start and stop (cycling) as this will reduce the motor life.

3. Cycling can occur on pressure units when the pressure tank pre-charge drops, or when there is a leak in the discharge plumbing.



## XI. Operation and maintenance

### 1. Diagnosis of the pump operation:

There are 3 indicator lights on the terminal box-Power (Green), Failure (Red) and On (Yellow). The diagnosis of the pump operating condition is as below:

- (1) Power (Green): It is always on when connected to power.
- (2) On (Yellow): Turns-on when tap is open indicates normal operation.
- (3) Failure (Red): Turns-on when tap is open indicates the pump is run dry.
- (4) On (Yellow): Turns on intermediately when tap is closed indicates pipe leak.

### 2. Periodically check the condition of the check valve and strainer (if used).

3. If the pump is to be inactive for long periods, it should be rinsed thoroughly with clean water, then, drained and stored in a dry place.

It has to be re-primed before start-up.

4. If the pump shaft is seized up after periods of inactivity, please place a screw driver from the motor end to rotate the shaft. It should free the pump shaft. ( See Fig 10 ) If this does not remedy the problem, the unit will need dismantling.

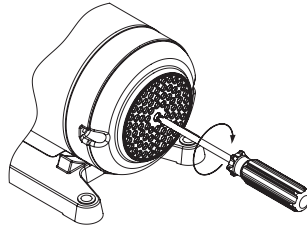

Fig. 10

5. Pressure tank air charge should be checked at regular intervals of every 6 months and after the pump has not been used for a prolonged period. To check the Tank pressure, turn off power, open the tap on discharge line to release pressure from the pump, unscrew the black plastic cover and place a pressure gauge on it as shown in Fig 11.

Pressure should be adjusted to the original pre-charge as follows:

HQ200: 20 psi (1.4 Kg/cm<sup>2</sup>)

HQ400: 22 psi (1.6 Kg/cm<sup>2</sup>)

HQ800: 25 psi (1.8 Kg/cm<sup>2</sup>)

HQ800H: 31 psi (2.2 Kg/cm<sup>2</sup>)

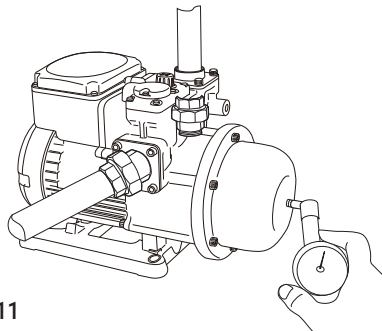

Fig. 11

6. When the flanges are removed for maintenance or any reason, please follow the following instructions for installation:
- a. Place the gasket to the flanges

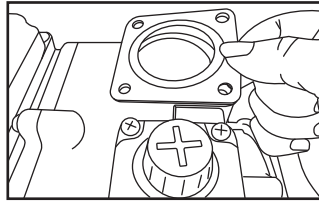
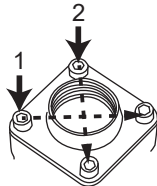

Fig. 12

- b. Install 4 screws to the flange and DO NOT tighten up at this time. When all 4 screws are in place; tighten them diagonally onto flange. DO NOT overtighten (recommended torque is 18~22 in-lbs)



Diagonal

Screws be tightened diagonally

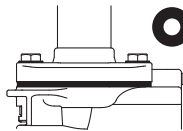

Pipe and flange are installed in a straight line

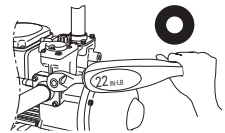

Screw torque is 18~22 in-lb

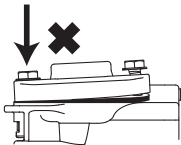

Do not tighten the screws unevenly

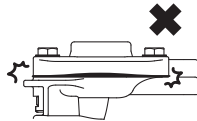

Do not over torque the screws

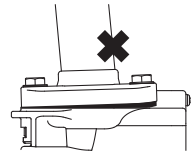

Pipeline must be straight

- c. Install inlet and outlet pipings to the unions and then connect them to pump flanges.

7. Please plug off when it is lack of water supply or pump is not in use for a long time.

## XII. Flooded Suction Performance Table

### HQ200

Inlet pressure (psi)	Flow rate				
	3 gpm	6 gpm	9 gpm	12 gpm	15 gpm
10	39	33	27	21	14
20	49	43	37	31	24
30	59	53	47	41	34

### HQ400

Inlet pressure (psi)	Flow rate						
	3 gpm	6 gpm	9 gpm	12 gpm	15 gpm	18 gpm	21 gpm
10	43	36	35	31	26	21	14
20	53	46	45	41	36	31	24
30	63	56	55	51	46	41	34

### HQ800

Inlet pressure (psi)	Flow rate									
	3 gpm	6 gpm	9 gpm	12 gpm	15 gpm	18 gpm	21 gpm	24 gpm	27 gpm	30 gpm
10	49	47	46	44	42	40	38	34	30	24
20	59	57	56	54	52	50	48	44	40	34
30	69	67	66	64	62	60	58	54	50	44
40	79	77	76	74	72	70	68	64	60	54

### HQ800H

Inlet pressure (psi)	Flow rate								
	3 gpm	6 gpm	9 gpm	12 gpm	15 gpm	18 gpm	21 gpm	24 gpm	27 gpm
10	72	67	61	56	50	45	39	29	14
20	82	77	71	66	60	55	49	39	24
30	92	87	81	76	70	65	59	49	34
40	102	97	91	86	80	75	69	59	44

### **XIII. Frequently asked questions:**

1. What causes the HQ to start?

The HQ has the built-in pressure switch and internal flow switch. Each of these can turn the pump on depending on water consumption. The pump will start when:

- The pressure is BELOW the pressure switch activation point. OR
- The flow rate is greater than 0.7 GPM.

The preset activation point for each model is provided in the pump specifications.

2. What causes the HQ to stop?

The flow switch is designed to automatically stop the HQ pump when flow drops to below 0.7 GPM. After the pump is shut off, the motor will stop in 6 seconds for HQ series. In addition, the HQ will be turned off in the event of dry-run or over temperature (trip at 131°F) alarm.

3. What is the purpose of the built-in pressure tank?

The pressure tank comes from the factory pressurized at approximately 20-31 psi (with the pump pressure at zero). It is designed to minimize motor startup due to small flow demand or minor leak of the pipeline.

HQ200: 20 psi (1.4 Kg/cm<sup>2</sup>)

HQ400: 22 psi (1.6 Kg/cm<sup>2</sup>)

HQ800: 25 psi (1.8 Kg/cm<sup>2</sup>)

HQ800H: 31 psi (2.2 Kg/cm<sup>2</sup>)

4. How is the dry-run and cycling condition determined and the protection provided?

The dry-run is defined when the motor is running AND the flow rate is less than 0.3 GPM AND when pressure is less than the pressure switch setting. The protection is provided: When the pump is run dry 1 minute, it will automatically shut off for 10 minutes and then attempts to restart. When all 3 attempts are failed, the pump will rest for 1 hour and then attempts to restart. This protection mode will be repeated until the water supply is back to normal.

In case the pump is cycling (on-and-off repeatedly) due to small flow (less than 0.3GPM), air pocket in the system, air loss in the pressure tank or leak in the pipeline, the protection is provided:

The pump will run for 6 seconds and stop for about 3 seconds. When the cycling mode repeats 15 times consecutively, the pump will rest for 1 hour. Then protection mode will start again until the problem is corrected.

Note: The pump can be reset anytime by removing the power plug.

5. What is the maximum inlet pressure allowed in the HQ?

The maximum internal system pressure allowed for HQ is 120 psi. The maximum inlet pressure when added to the HQ pressure must not exceed 120 psi. For example with a 40 psi inlet pressure supplied to the HQ800H, internal system pressures can reach approximately 104 psi (64 + 40 psi).

Additionally, if inlet pressures exceed the built-in pressure switch activation point (20-31 psi factory default), the pressure switch will be unable to function, and the ability to turn the HQ on at low flow rates will be lost. In this situation, only the flow switch will be able to turn the HQ on at flow rates above 0.7 gpm.

## XIV. Dimensions: (in.)

### HQ200/400

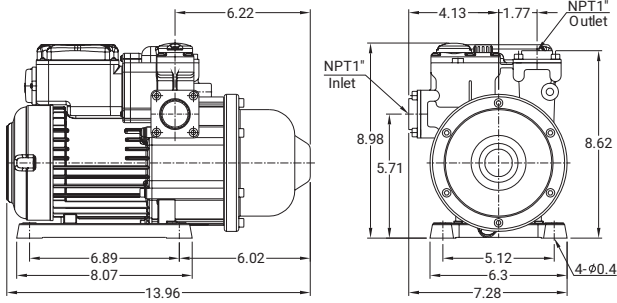

### HQ800/800H

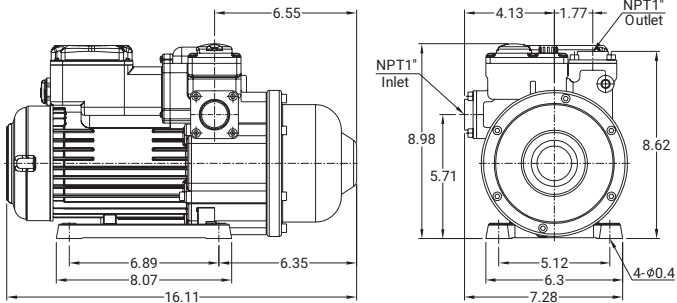

## XV. Specification: 60Hz

Model	Power (HP)	Phase (Ø)	Voltage (V)	Amp's (A)	Preset activation pressure (psi)	Max discharge pressure (psi)	Q max. (GPM)
HQ200	¼	1	115 or 230	4.0 or 2.0	20	32	15.8
HQ400	½	1	115 or 230	6.0 or 3.0	22	37	21.1
HQ800	1	1	115 or 230	10.0 or 5.0	25	38	31.7
HQ800H	1	1	115 or 230	10.0 or 5.0	31	64	26.4

## XVI. Troubleshooting



Before starting work on the pump, make sure that the electricity supply has been switched off and that it cannot be accidentally switched on.

Problem	Cause	Remedy
1. Pump does not start	a. No power supply	Connect the electricity supply
	b. Too low/high voltage	Check if supply voltage is within $\pm 10\%$
	c. No water consumption	Open a tap
	d. Seized-up pump	Place a screwdriver against the shaft end of the motor to check if the rotor will spin freely, and contact your pump supplier.
2. Pump cuts out during operation	a. Seized-up pump	Same as above
	b. Overloaded motor	Turn off the power supply and restart or contact your pump supplier.
	c. Poor water supply	Check if pump suction inlet is blocked.
	d. The protection for pump dry run or cycling is activated.	Check the detailed information per XII (Frequently asked questions).
3. Pump starts when no water is consumed	a. Existing pipe is leaking	Fix the leakage.
	b. Defective check valve	Clean or replace a new one.
	c. Pipe suck in air.	Check the suction pipe and water supply.
4. Pump starts and stops too frequently	a. Leakage in suction pipe or air in the water.	Check the suction pipe and water supply.
	b. Discharge flow is too low.	Set your tap on a higher water flow.
5. Electric shock	a. Defective ground connection	Correct the ground connection.
6. Pump does not stop when water is not consumed	a. Poor water supply or air suck in.	1. Turn off the power supply and open the refilling plug to release the air. Then restart. 2. In case of long suction pipes, turn off the power and make sure if water supply is adequate.
	b. Defective check valve.	Clean or replace with a new valve.
7. Pump runs normal but with very low discharge flow	a. Poor water supply	Check if water supply is adequate and if the suction pipe is blocked.
8. Green and Yellow lights turn-on when tap is open		Pump is in normal operation
9. Green and Red lights turn-on when tap is open	Pump is in dry run	Shut off the power, and check water source
10. Green light is on and Yellow light is turn-on intermediately when tap is closed.	Pump is cycling most likely because of pipe leak.	Fix the pipe leak

# Limited Warranty

Products manufactured by Walrus Pumps Co (Walrus) are warranted to the first user only to be free of defects in material and workmanship for a period of 12 months from date of installation, but no more than 24 months from date of shipment. Walrus' liability under this warranty shall be limited to repairing or replacing at our election, without charge, FOB Walrus' distribution center or authorized service agent. Walrus will not be liable for any cost of removal, installation, transportation or any other charges that may arise in connection with warranty claim.

The warranty period commences on the date of original purchase of the equipment. Proof of purchase and installation date, failure date, and supporting installation data must be provided when claiming repairs under warranty.

This warranty is subject to due compliance by the original purchaser with all directions and conditions set out in the installation and operating instructions. Failure to comply with these instructions, damage or breakdown caused by fair wear and tear, negligence, misuse, incorrect installation, inappropriate chemicals or additives in the water, inadequate protection against freezing, rain or other adverse weather conditions, corrosive or abrasive water, lightning or high voltage spikes or through unauthorized persons attempting repairs are not covered under warranty.

Walrus will not be liable for any incidental or consequential damages, losses, or expenses, arising from installation, use, or any other causes. There are no express or implied warranties, including merchantability or fitness for a particular purpose, which extend beyond those warranties described or referred to above.

Certain states do not permit the exclusion or limitation of incidental or consequential damages or the placing of limitations on the duration of an implied warranty, therefore, the limitations or exclusions herein may not apply. This warranty sets forth specific legal rights and obligations, however, additional rights may exist, which may vary from state to state.

Supersedes all previous publications



**WALRUS**  
PUMP



[walrusamerica.com](http://walrusamerica.com)

**Walrus America Inc.**