

## Limited Warranty

Products manufactured by Walrus Pumps Co (Walrus) are warranted to the first user only to be free of defects in material and workmanship for a period of 12 months from date of installation, but no more than 24 months from date of shipment. Walrus' liability under this warranty shall be limited to repairing or replacing at our election, without charge, FOB Walrus' distribution center or authorized service agent. Walrus will not be liable for any cost of removal, installation, transportation or any other charges that may arise in connection with warranty claim.

The warranty period commences on the date of original purchase of the equipment. Proof of purchase and installation date, failure date, and supporting installation data must be provided when claiming repairs under warranty.

This warranty is subject to due compliance by the original purchaser with all directions and conditions set out in the installation and operating instructions. Failure to comply with these instructions, damage or breakdown caused by fair wear and tear, negligence, misuse, incorrect installation, inappropriate chemicals or additives in the water, inadequate protection against freezing, rain or other adverse weather conditions, corrosive or abrasive water, lightning or high voltage spikes or through unauthorized persons attempting repairs are not covered under warranty.

Walrus will not be liable for any incidental or consequential damages, losses, or expenses, arising from installation, use, or any other causes. There are no express or implied warranties, including merchantability or fitness for a particular purpose, which extend beyond those warranties described or referred to above.

Certain states do not permit the exclusion or limitation of incidental or consequential damages or the placing of limitations on the duration of an implied warranty, therefore, the limitations or exclusions herein may not apply. This warranty sets forth specific legal rights and obligations, however, additional rights may exist, which may vary from state to state.

Supersedes all previous publications



**Walrus America Inc**

9808 Whithorn Drive, Houston, TX 77095  
Web: [www.walrusamerica.com](http://www.walrusamerica.com)

P099C021U006-00



**TS400C**  
**TS800C**

## **Auto Pressure Control Pump Instruction Manual**



ISO 9001 Certified

**Walrus America Inc**

# EC Declaration of Conformity

Manufacturer:

Walrus Pump Co., Ltd.

Address:

No. 83 -14, Dapiantou, Sanjhieh Township, Taipei County 252,  
Taiwan

Declare that the machinery described:

Name : Water Pump

Model : TS400C, TS800C

Conform to the following directive:

98/37/EC-----Machinery directive

2006/95/EC—Low voltage directive

2004/108/EC----EMC (Electromagnetic compatibility) directive

Refer to the following standards:

EN ISO 12100-1:2003      EN ISO 12100-2:2003

EN1050:1996

EN60335-1:2001      EN 809:1998

EN60335-2-41:2001

EN61000-6-2      EN61000-6-3

R&D department manager: Kao Tien-chuan

Manager: *Kao Tien chuan*

Please study all instructions carefully before installing your new system, as failures caused by incorrect installation and operation are not covered by the warranty.

## I. Product

The Walrus TS400C & TS800C is a compact booster systems equipped with auto pressure controller. The controller provides constant pressure and flow which will automatically start and stop the pump when the tape is open and close. This feature also provides dry run protection.

## II. Applications

Boosting pressure for:

\*Homes where the incoming city water pressure is too low.

\*Portable water supply or underground water.

\*Washing/cleaning system

\*Irrigation system

### 1. CONSTRUCTION CHARACTERISTICS

-Special non return valve to avoid surges  
-Security system avoiding the pump dry run without water.

-Pressure gauge

-Manual start swithch(RESET)

-Tension LED (POWER)

-Pump-working LED(ON)

-Security system LED (FAILURE)

### 2. Operation Limits

Max. Flow rate: 21.1 GPM

Max. total head: 147.6 ft(64 psi)

Preset activation pressure: 30~40 psi

Max. liquid temperature: 104°F(40°C)

Max. ambient temperature: 104°F(40°C)

Max. system pressure: 120 psi

Inlet size: 1" NPT

Outlet size: 1" NPT

## III. Installation

### 3.1 Installation site

3.1.1. Choose a site with sold foundation, dry and good ventilation. Please provide accessible space around the pump and leave at least 12"(30cm) clearance between your motor end to the wall.

3.1.2. The Walrus TS400C/TS800C pumps are for indoor use only. When used outdoors, the pump should be in an enclosure which is out of direct sunlight, water proof, frost free and has adequate ventilation. Make sure the enclosure is compliant with local regulations.

3.1.3. Please install the pump as close to water source as possible. The long suction pipes may cause pressure loss.

3.1.4. Ensure all connections are completely sealed using thread tape only. An air leak on the suction may cause your pump running without discharge flow.

3.1.5. Make sure the environment of your pump site free from abrasive liquid, PVC, metal chips or anything else that will damage your equipment.

3.1.6. The pump has a built-in check valve; please do not install any other valve on the suction.

3.1.7. For best performance use pipes at least the same diameter as the pump's inlet and delivery outlet openings. It is recommended to use metal hose for outlet piping.

3.1.8. Do not let your pump run when there is no water available or water temperature is over 104°F (40°C).

3.1.9. For your safety, please hook up a circuit breaker and connect grounding connections to the pump in accordance with local regulations.

## IV. Wiring diagram

### WARNING:

Risk of Electric Shock - This pump is supplied with a grounding conductor and grounding-type attachment plug. To reduce the risk of electric shock, be certain that it is connected only to a properly grounded, grounding-type receptacle".



This mark located outside the connection box is a warning for an electrical hazard.

Before operation, please check if the voltage is correct and be sure if the circuit breaker and grounding connectors are all connected in accordance with local regulations.

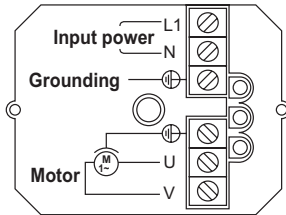

## V. Operation

Never run pump when no water is available. When you have successfully installed the pump and fill the chamber with water, please follow the instructions on Fig. 2 to start up the operation.

5.1.1. Remove the filling plug and fill the chamber with water and then replace the plug.

a. Remove the filling plug

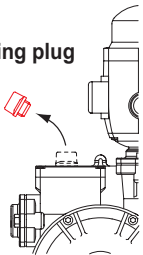

b. Fill water in chamber

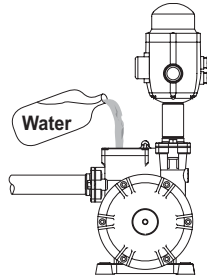

c. Replace the filling plug

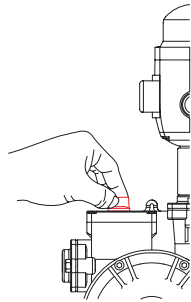

Fig. 2

5.1.2. When the pump inlet is lower than the water supply level, please remove the filling plug to let water back flow to the chamber. It can be repeated as many times as necessary till the air is completely released from system. Then, replace your filling plug.

5.1.3. For start up of the first operation or after long time inactivity, please place a screwdriver against the shaft at motor end and turn clockwise to see if rotor spins freely (Fig. 3). If it is, you are free to run the pump.

5.1.4. When the pump is running normally, please measure the running current with a wattmeter. If it exceeds the rated value on nameplate, please check if your power supply voltage is within  $\pm 10\%$ . Please contact your pump supplier if you are not sure how to correct it.

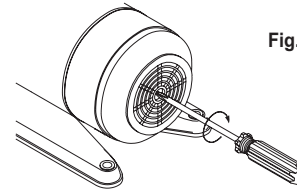

Fig. 3

- 5.2.1. Be sure that the pump is correctly primed, and then gently open the tap.
- 5.2.2. Connect the controller to electric supply. The LED light (POWER) will be illuminated.
- 5.2.3. After startup for 20-25 seconds, the controller will reach the maximum pressure provided by the pump, and the LED light(ON) will be illuminated.
- 5.2.4. If there is no discharge flow after a few minutes, please turn off the pump and repeat the Process of 5.2.1. Turn the pump on and off several times until it is working normally.
- 5.2.5. Close the tap and the pump will stop in 7-9 seconds. All indicator lights should be off except the LED light(POWER)

## VI. Maintenance and service

Under normal operating conditions, the pump is maintenance free. It is especially critical, when the ambient temperature reaches 104°F (40°C), to keep your pump site dry and maintain good ventilation. It is always advisable to provide accessible space around the pump.

You may refer to troubleshooting check list to find out a quick solution for your problems. However if the problems are still existed after your attempts or you need other services, please contact your pump supplier. Do not attempt to disassemble the pump as it will void your warranty.

## VII. Troubleshooting



Before starting troubleshooting the pump, make sure that the power has been switched off and that it cannot be accidentally switched on.

Problem	Cause	Remedy
1. Pump doesn't start:	a. Not enough water supply, and the LED light (FAILURE) is illuminated.	Check the water supply and restart the pump by pressing the reset switch(RESET).
	b. Pump is blocked: LED (FAILURE) light is illuminated and by pressing the manual start switch (RESET), the LED (ON) is illuminated; but the pump doesn't work.	Consult your dealer.
	c. Failure of the electronic circuit board.	Switch off power supply, wait a few seconds and turn it on again. If the pump doesn't start immediately, it needs to replace the circuit board.
	d. No electrical supply.	Check the electrical supply. The LED light (POWER) should be illuminated.
	e. Pump pressure is too low and the LED light (FAILURE) is illuminated.	Check if the pump max pressure is at least 11psi(0.8kg/cm <sup>2</sup> ) higher than the starting pressure of the controller.
	f. Air Pocket in the system, and LED(FAILURE) is illuminated.	Check if all pipe joints are tightened. Reprime the pump to force the air out of the system.
2. Pump doesn't stop:	a. Water leakage higher than 0.3gpm(1.2 lpm).	Check the system,the tap,etc, and fix the leak.
	b. Manual start switch (RESET) is blocked.	1. Press it for several times. 2. Consult your dealer if the problem persists.
	c. Failure of the electronic circuit board.	Replace it.
3. The pump starts and stops frequently.	a. Leakage in the system.	Stop the leak.

## VIII. Dimensions: (in.)

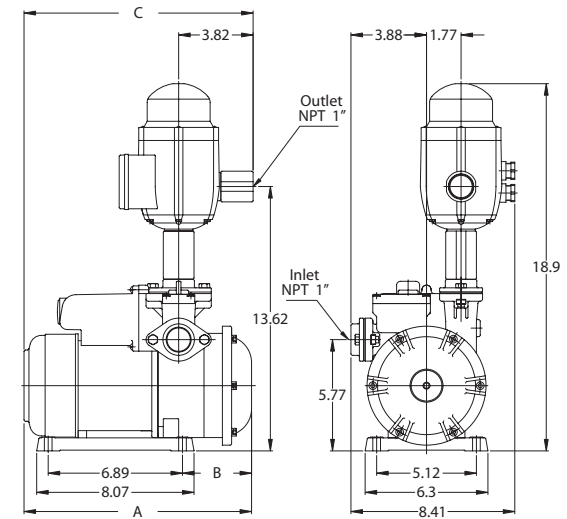

Model	A (in.)	B (in.)	C (in.)
TS400C	11.69	3.54	11.75
TS800C	13.82	3.48	13.56

## IX. Flooded Suction Performance Table

TS400C

Inlet pressure (psi)	Flow rate				
	3 gpm	6 gpm	9 gpm	12 gpm	15 gpm
10	48	41	33	24	15
20	58	51	43	34	25
30	68	61	53	44	35

TS800C

Inlet pressure (psi)	Flow rate						
	3 gpm	6 gpm	9 gpm	12 gpm	15 gpm	18 gpm	21 gpm
10	69	64	57	50	41	30	11
20	79	74	67	60	51	40	21
30	89	84	77	70	61	50	31