

## Limited Warranty

Products manufactured by Walrus Pumps Co (Walrus) are warranted to the first user only to be free of defects in material and workmanship for a period of 12 months from date of installation, but no more than 24 months from date of shipment. Walrus' liability under this warranty shall be limited to repairing or replacing at our election, without charge, FOB Walrus' distribution center or authorized service agent. Walrus will not be liable for any cost of removal, installation, transportation or any other charges that may arise in connection with warranty claim.

The warranty period commences on the date of original purchase of the equipment. Proof of purchase and installation date, failure date, and supporting installation data must be provided when claiming repairs under warranty.

This warranty is subject to due compliance by the original purchaser with all directions and conditions set out in the installation and operating instructions. Failure to comply with these instructions, damage or breakdown caused by fair wear and tear, negligence, misuse, incorrect installation, inappropriate chemicals or additives in the water, inadequate protection against freezing, rain or other adverse weather conditions, corrosive or abrasive water, lightning or high voltage spikes or through unauthorized persons attempting repairs are not covered under warranty.

Walrus will not be liable for any incidental or consequential damages, losses, or expenses, arising from installation, use, or any other causes. There are no express or implied warranties, including merchantability or fitness for a particular purpose, which extend beyond those warranties described or referred to above.

Certain states do not permit the exclusion or limitation of incidental or consequential damages or the placing of limitations on the duration of an implied warranty, therefore, the limitations or exclusions herein may not apply. This warranty sets forth specific legal rights and obligations, however, additional rights may exist, which may vary from state to state.

Supersedes all previous publications



# WALRUS®

**Walrus America Inc**

9808 Whithorn Drive, Houston, TX 77095

Web: [www.walrusamerica.com](http://www.walrusamerica.com)

C099C003U004-02

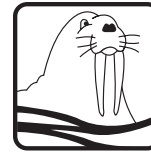

# WALRUS®

## *TPH Series*

## **MULTISTAGE CENTRIFUGAL PUMP Instruction Manual**



ISO 9001 Certified

## **Walrus America Inc**

# EC Declaration of Conformity

Manufacturer:

Walrus Pump Co., Ltd.

Address:

No. 83 -14, Dapiantou, Sanjhieh Township, Taipei County 252, Taiwan

Declare that the machinery described:

Name : Water Pump

Model : TPH Series

Conform to the following directive:

98/37/EC-----Machinery directive

2006/95/EC—Low voltage directive

2004/108/EC----EMC (Electromagnetic compatibility) directive

Refer to the following standards:

EN ISO 12100-1:2003      EN ISO 12100-2:2003

EN1050:1996

EN60335-1:2001      EN 809:1998

EN60335-2-41:2001

EN61000-6-2      EN61000-6-3

R&D department manager: Kao Tien-chuan

Manager:

*Kao Tien chuan*

## TPH Instruction Manual

Please study all instructions carefully before installing your new system, as failures caused by incorrect installation and operation are not covered by the warranty.

### 1. General Data:

#### 1.1 Applications

The TPH Series are modernly designed with quiet and high efficient operation pumps, suitable for dependable water transfer, circulating or booster service. It works for clean or other liquids without abrasive matters.

- Industrial circulation system
- Washing/cleaning system
- Pressure boosting system
- Water/liquid transfer
- Agricultural irrigation
- Air-conditioning

#### 1.2 Pump Construction:

Horizontal multi-stage centrifugal pump, non self-priming, co-axial pump/motor design, impellers mounted on extended motor shaft. All parts in contact with the pumped liquid are made of stainless steel.

#### 1.3 Operation conditions:

Ambient temperature: Max. 104°F (40°C )

Liquid temperature range: 32°F (0°C) to 194°F (90°C)

Operating pressure: Max. 142 psi

Inlet pressure: Max. 85 psi

## 2. Installation and piping

### 2.1 Installation site

- 2.1.1 For secure operation, please mount and bolt the pump base to the foundation.
- 2.1.2 Select a dry and good ventilated site and provide accessible space around the pump for future maintenance and service.
- 2.1.3 Make sure the ambient temperature is below 104°F(40°C) and the flowing liquid temperature does not exceed 194°F(90°C) .
- 2.1.4 Do not operate the pump under explosive environment.
- 2.1.5 When the pump is installed outside, please provide a suitable cover to protect it from

weather and frost. Please do not allow any foreign objects fall into the motor fan cover.

- 2.1.6 Horizontal installation is recommended. When it is installed in other positions, please provide drain holes to allow drainage of the pump.

### 2.2 Electrical connection

- 2.2.1  This mark located outside the connection box is a warning for an electrical hazard.

- 2.2.2 The electrical connection should be carried out in accordance with local regulations. The operating voltage and frequency are marked on the nameplate. Please make sure that these data match with your job requirement. For your safety, be sure the circuit breaker is in your system and grounding is properly connected to prevent from electric shock.

- 2.2.3 Three phase motors must be connected to a motor starter for protection of overload and single phase running. Please be sure if the direction of rotation is correct. For three phase motor you can reverse the direction of rotation by interchanging any two of the incoming supply wires. Before your first operation, please place a allen wrench against the shaft at motor end and turn by the direction of rotation to see if rotor spins freely.

- 2.2.4 The position of the connection box is adjustable. It can be turned either side before the pump is installed. The preset position from the factory is on the top of the motor. To change the position of the connection box, please remove the bolts on the motor frame (4 bolts which are bolted into the chamber) and turn the stator housing to the required position. Replace the screws and tighten securely.

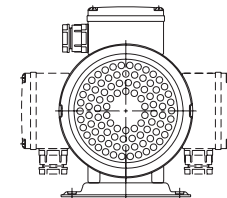

- 2.3 The pump should be installed so that the suction pipe is as short and the suction lift as small as possible.
- 2.4 When you draw liquid from the same level of the pump suction inlet, please allow a slope from the liquid source to your suction inlet to avoid air sucked in. If it is to pump liquid from a level lower than the pump suction inlet, a foot valve check valve must be fitted to the end of the suction pipe.
- 2.5 Please select the pipe size specified in the specifications. Smaller piping will cause considerable pressure loss and affect pump efficiency.
- 2.6 All piping joints must be completely tight. Leakage in suction piping may result in the loss of the suction capability. Leakage in discharge piping may cause the "cycling" of the pump.
- 2.7 Please do not allow any foreign objects (chewing gum, dirt, and sand etc.) fall into the pump or motor.
- 2.8 The pump lifting capacity is related to the temperature of flowing liquid. Under normal flowing temperature (68°F - 86°F), it will lift up to 16Ft. At high temperature operation (over 140°F), the pump must be installed at the level lower than the liquid source or the pump inlet pressure must be higher than 1 atmosphere (15 PSI).
- 2.9 It is extremely dangerous to run the pump against a closed discharge valve, because it will cause extremely high liquid flow temperature and damage your pump. You may connect a bypass/a drain to the discharge pipe to allow a minimum liquid flow through the pump.
- 2.10 Metal piping is recommended when the operations require high lifting head or high liquid temperature.
- 2.11 In systems with hot liquids (over 140°F), extra caution should be exercised to prevent from personal injury caused by escaping water.
- ### 3. Operation instructions
- 3.1 For booster systems where the liquid level on the suction side is above the pump inlet, please remove the filling plug and let water back flow to the chamber. For pumping from tanks and wells where the liquid level on the suction side is below the pump inlet, please

remove the filling plug and pour water through the chamber. Be sure suction pipe and pump are completely filled with liquid and vented. Replace the plug after water is filled.

- 3.2 Double check if the voltage and wiring connection are correct before you switch on the pump. Your pump should be operating shortly.
- 3.3 If there is no discharge flow after a few minutes, please turn off the pump and repeat the Process of 3.1 Turn the pump on and off several times until it is working normally.
- 3.4 When pump is working on normal condition, measure the motor current and check it with the nameplate value. If it exceeds the rated value, please reduce the lifting capacity or fully open the valve.
- 3.5 When pump is not in use for a period, it should be drained by removing the priming and drain plugs. For start up after long time inactivity, please check if the impeller and mechanical seal are free. If they are locked up by sand, rust or something else please clean them up.

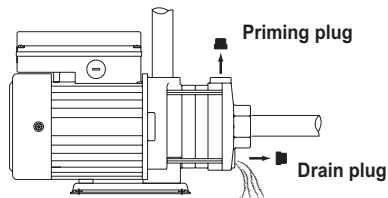

### 4. Sound pressure level

Motor (HP)	LA dB(A)
1/2	<70
3/4	<70
1	<70
1 1/2	71
2	72
3	76
5	78
7 1/2	78
10	78
15	78

### 5. Wiring diagram

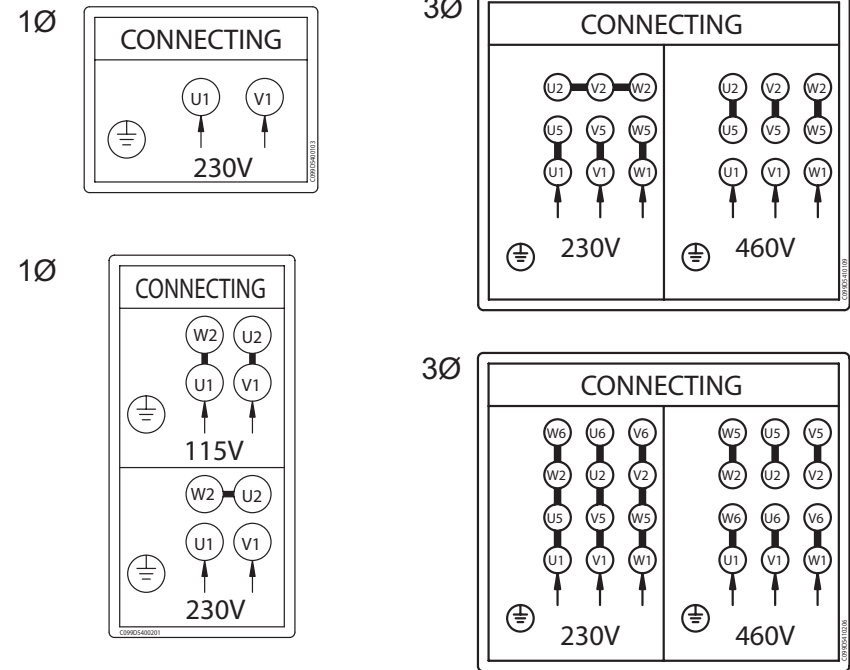

### 6. Fault finding

(Make sure to disconnect the power before attempting to diagnose any fault.)

Fault	Cause
1. Pump does not start	1. Check if electrical power source, fuse or circuit breaker failed.
	2. Check if pump is locked up by sand, rust or any foreign objects.
	3. Check if the motor is defective due to overload or other causes.
2. Pump runs at reduced capacity or no discharge water	1. If it is a three phase motor, please check if the direction of rotation is correct.
	2. Check if the inlet source is sufficient, the suction lift is not too great and the temperature is within the normal range.
	3. Check if there is any leakage in suction pipe, check valve works normal and mechanical seal is not defective etc.
3. Pump stops during operation	1. Motor overheat due to excessive suction lift or too high liquid temperature.
	2. Control circuit has cut out (pressure switch or level controller).

### Dimensions ( TPH 2/4 )

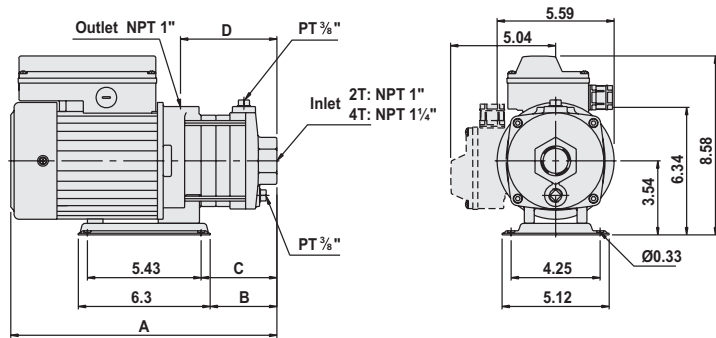

#### TPH 2T

Model	A(in.)	B(in.)	C(in.)	D(in.)
TPH 2T 1K	12.01	1.81	2.91	3.90
TPH 2T 2K	12.01	1.81	2.91	3.90
TPH 2T 3K	12.72	3.19	3.62	4.61
TPH 2T 4K	13.43	3.90	4.33	5.31
TPH 2T 5K	15.71	4.61	5.04	6.05
TPH 2T 6K	16.42	5.31	5.75	6.73

#### TPH 4T

Model	A(in.)	B(in.)	C(in.)	D(in.)
TPH 4T 2K	12.36	2.83	3.27	4.29
TPH 4T 3K	15.00	3.90	4.33	5.31
TPH 4T 4K	16.06	4.96	5.39	6.38
TPH 4T 5K	17.13	6.02	6.46	7.44
TPH 4T 6K	19.37	7.09	7.52	8.54

### Dimensions ( TPH 25T )

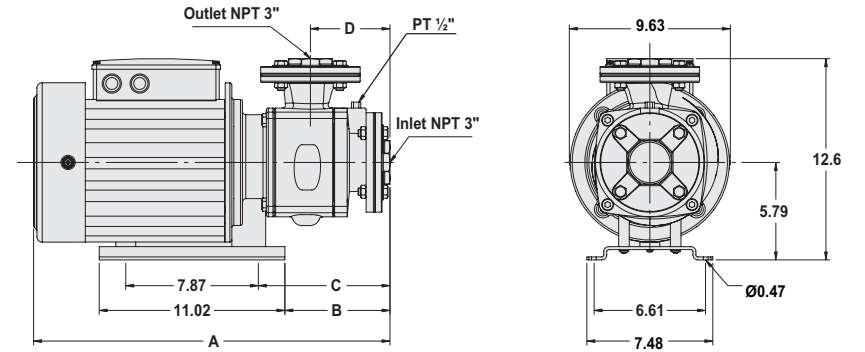

#### TPH 25T 60Hz

Model	A(in.)	B(in.)	C(in.)	D(in.)
TPH 25T 2K	21.16	6.24	7.81	4.72
TPH 25T 3K	23.52	8.60	10.18	7.09
TPH 25T 4K	23.52	8.60	10.18	7.09
TPH 25T 5K	27.85	10.96	12.54	9.45
TPH 25T 6K	27.85	10.96	12.54	9.45

### Dimensions ( TPH 8/12 )

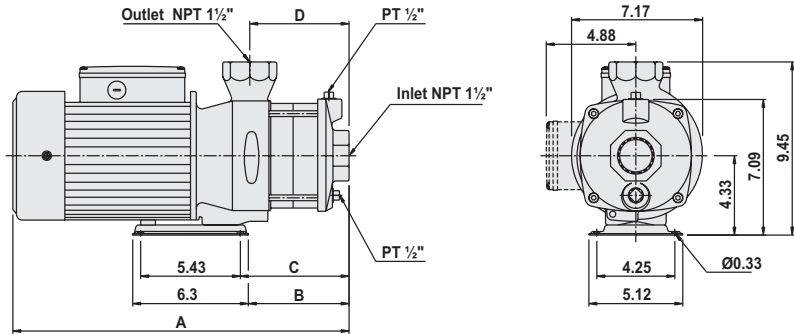

#### TPH 8T

Model	A(in.)	B(in.)	C(in.)	D(in.)
TPH 8T 2K	13.19	3.03	3.46	2.95
TPH 8T 2.5K	16.02	4.29	4.72	4.21
TPH 8T 3K	16.02	4.29	4.72	4.21
TPH 8T 4K	17.13	4.29	4.72	4.21
TPH 8T 5K	18.39	5.55	5.98	5.47

#### TPH 12T

Model	A(in.)	B(in.)	C(in.)	D(in.)
TPH 12T 1K	13.19	3.03	3.46	2.95
TPH 12T 2K	14.76	3.03	3.46	2.95
TPH 12T 3K	17.13	4.29	4.72	4.21
TPH 12T 4K	17.13	4.29	4.72	4.21

### Dimensions ( TPH 50T )

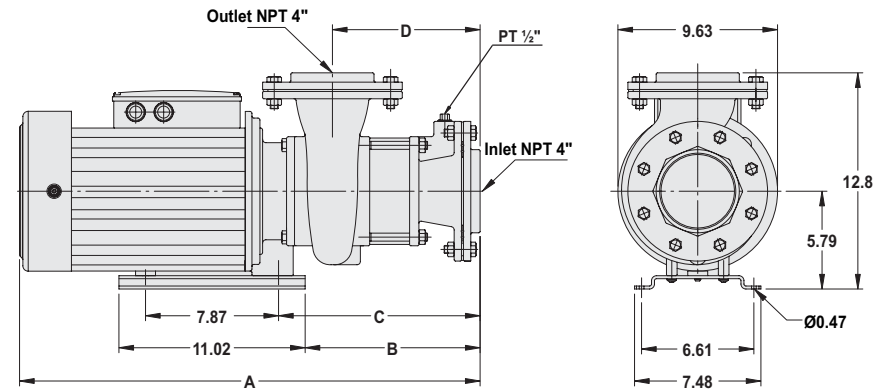

#### TPH 50T 60Hz

Model	A(in.)	B(in.)	C(in.)	D(in.)
TPH 50T 2.5KF	22.93	7.99	9.57	6.38
TPH 50T 4KF	27.26	10.35	11.93	8.74
TPH 50T 5KF	29.23	10.35	11.93	8.74