

## Limited Warranty

Products manufactured by Walrus Pumps Co (Walrus) are warranted to the first user only to be free of defects in material and workmanship for a period of 12 months from date of installation, but no more than 24 months from date of shipment. Walrus' liability under this warranty shall be limited to repairing or replacing at our election, without charge, FOB Walrus' distribution center or authorized service agent. Walrus will not be liable for any cost of removal, installation, transportation or any other charges that may arise in connection with warranty claim.

The warranty period commences on the date of original purchase of the equipment. Proof of purchase and installation date, failure date, and supporting installation data must be provided when claiming repairs under warranty.

This warranty is subject to due compliance by the original purchaser with all directions and conditions set out in the installation and operating instructions. Failure to comply with these instructions, damage or breakdown caused by fair wear and tear, negligence, misuse, incorrect installation, inappropriate chemicals or additives in the water, inadequate protection against freezing, rain or other adverse weather conditions, corrosive or abrasive water, lightning or high voltage spikes or through unauthorized persons attempting repairs are not covered under warranty.

Walrus will not be liable for any incidental or consequential damages, losses, or expenses, arising from installation, use, or any other causes. There are no express or implied warranties, including merchantability or fitness for a particular purpose, which extend beyond those warranties described or referred to above.

Certain states do not permit the exclusion or limitation of incidental or consequential damages or the placing of limitations on the duration of an implied warranty, therefore, the limitations or exclusions herein may not apply. This warranty sets forth specific legal rights and obligations, however, additional rights may exist, which may vary from state to state.

Supersedes all previous publications



**Walrus America Inc**

9808 Whithorn Drive, Houston, TX 77095  
Web: [www.walrusamerica.com](http://www.walrusamerica.com)

C099C016U0005-00



***TPH-C* Series**

## ***Auto Pressure Control Pump Instruction Manual***



ISO 9001 Certified

**Walrus America Inc**

# EC Declaration of Conformity

Manufacturer:

Walrus Pump Co., Ltd.

Address:

No. 83 -14, Dapiantou, Sanjih Township, Taipei County 252, Taiwan

Declare that the machinery described:

Name : Water Pump

Model : TPH Series

Conform to the following directive:

98/37/EC-----Machinery directive

2006/95/EC—Low voltage directive

2004/108/EC----EMC (Electromagnetic compatibility) directive

Refer to the following standards:

EN ISO 12100-1:2003      EN ISO 12100-2:2003

EN1050:1996

EN60335-1:2001      EN 809:1998

EN60335-2-41:2001

EN61000-6-2      EN61000-6-3

R&D department manager: Kao Tien-chuan

Manager:

*Kao Tien chuan*

## TPHC Instruction Manual

Please study all instructions carefully before installing your new system, as failures caused by incorrect installation and operation are not covered by the warranty.

### I. Product

The electronic controller enables the pump to start and stop automatically when opening or closing tap or valve of the system. The controller enables the pump to deliver a constant flow of water and reduce the inconvenience of pressure variation during operation.

#### 1. Construction characteristics

- Special non return valve to avoid surges.
- Protect the pump against dry run.
- Provide with manual start switch(RESET).
- Provide indicators for normal or system fault.

#### CAUTION

This pump has been tested to water only.

#### 2. Operating conditions

Max. flow rate : 38.3 GPM

Max. total head: 236 Ft (102 psi)

Preset activation pressure : 40 psi  
(TPH4T2KC : 21 psi)

Max. liquid temperature: 140 °F

Max. ambient temperature: 104 °F

Max. system pressure: 142 psi

Inlet size: 2T - 1" NPT  
4T - 1 1/4" NPT

Outlet size: 1" NPT

### II. Installation

#### I. Choosing a site:

- For secure operation, the pump should be horizontally mounted on a firm base.
- Select a dry and good ventilated site and provide accessible space around the pump for maintenance and service.
- Make sure the ambient temperature is below 104°F(40°C) and the liquid temperature does not exceed 140°F (60°C) .
- Do not operate the pump under explosive environment.
- When the pump is installed outside, please provide a house to protect it from weather and frost. Please do not allow any foreign objects fall into the motor fan cover.

2. Horizontal installation is recommended.

3. Installation of auto controller:

- Place gasket (provided in plastic bag) into the top of stainless steel union and attach auto controller onto the union. DO NOT tighten!

- After positioning discharge of auto controller at desired angle, then firmly hand tighten union and auto controller together.

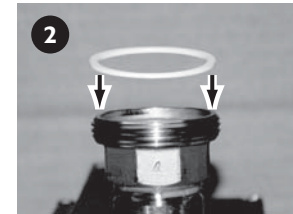
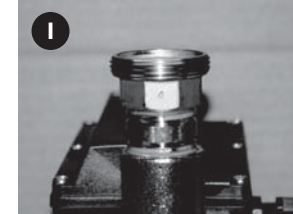

Place gasket into the union (gasket provided in plastic bag).

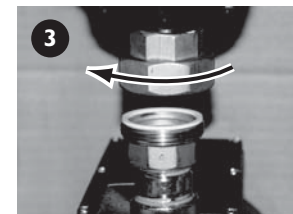

Attach auto controller onto the union.

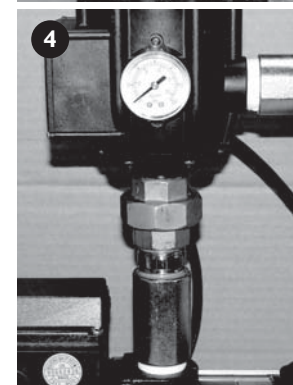

After positioning discharge of auto controller, hand tighten them together.

#### 4. Electrical connection

- This mark located outside the connection box is a warning for an electrical hazard.



- The electrical connection should be carried out in accordance with local regulations.  
The operating voltage and frequency are marked on the nameplate, please make sure that these data match with your job requirement. For your safety, be sure to connect a circuit breaker to your system. The grounding should be properly connected to prevent from electrical shock.

- For having the pump has more efficient operation, it is highly recommended that install the pump close to water source.
- When draw liquid from the same level of the pump suction inlet, please allow a downward slope from the liquid source to the pump suction inlet to avoid air sucked in. If it is to pump liquid from a level lower than the pump suction inlet, a foot valve must be fitted to the end of the suction pipe.
- All piping joints must be completely tight. Leakage in suction piping may result in the loss of the suction capability. Leakage in discharge piping may cause the "cycling" of the pump.
- Please do not allow any foreign objects (chewing gum, dirt, and sand etc.) fall into the pump or motor.
- Please select the pipe size specified in the specifications. Smaller pipe will cause considerable pressure loss and affect pump efficiency.

### III. Operation Instructions

- Prim the pump before start up  
Remove priming plug and fill chamber and suction line (on flood suction, simply open ball valve to pump). When full, replace priming plug.
- Connect power cord to power supply, the LED light (POWER) will be illuminated.
- Connection to Water Source:
  - Water source from cistern or storage tank  
No need to adjust the preset pressure except TPH4T2KC which is required to adjust down to 20 psi.
  - Water source from city or pressure tank  
There will be an inlet pressure added to the pump and is required to satisfy the following two criteria:
    - The inlet pressure add to the pump pressure must not exceed 140 psi.

- The inlet pressure must be 11 psi lower than the pump max pressure.
  - When inlet pressure is higher than the factory preset starting pressure of 40 psi, it is required to adjust the pressure. Please READ THE WARNING before you adjust the pressure setting.

The max inlet pressure is as follows:

Model	Max inlet pressure (PSI)	Max pump pressure (PSI)
TPH2T3K(S)C	41	52
TPH2T4K(S)C	60	71
TPH2T5K(S)C	52	88
TPH2T6K(S)C	38	102
TPH4T2K(S)C	24	35
TPH4T3K(S)C	41	52
TPH4T4K(S)C	60	71
TPH4T5K(S)C	52	91

### Warning

- **The inlet pressure will add to the pump max pressure to be the system pressure. When the total system pressure exceeds the local code limits for home pressure, it is required to install a pressure reducing valve to reduce the inlet pressure.**
  - **Pressure adjustment will only change the -starting pressure (cut in pressure); in stead of discharge pressure.**
  - **The auto controller is only able to handle the load up to 10 Amp. TPH4T5K(S)C can not be used for over 30 GPM flow rate**
  - **The starting pressure of TPH4T2K(S)C needs to be adjusted to 25 psi or lower to enable automatic on-and-off function.**
- After startup for 20-25 seconds, the controller will reach the maximum pressure provided by the pump, and the LED light (ON) will be illuminated.
  - If there is no discharge flow after a few minutes, please turn off the pump and repeat the process of 1. Turn the pump on and off several times until it is working normally.
  - Close the tap and the pump will stop in 7-9 seconds. All indicator lights should be off except the LED light (POWER).

- For small flow operation (below 0.5 GPM), it is recommended to install a pressure tank (3 Gallon or larger) on discharge to prevent from cycling. Set the tank pressure 7 psi lower than the starting pressure.

### 8. Pressure adjustment

Reduce pressure  Increase pressure

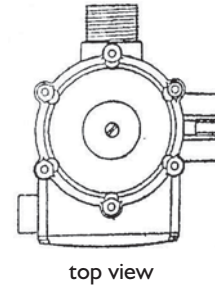

- When pump is not in use for a period of time, it should be drained by removing the priming and drain plugs. For start up after long time inactivity, please check if the rotor spins freely. If it is locked up, please dismantle the pump head and clean the impellers and other parts inside.

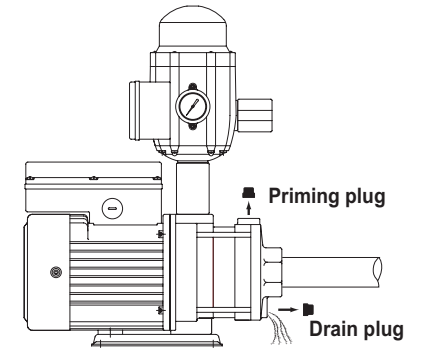

### IV. Performance Table for Suction Lift

Model	Discharge pressure in psi	Capacity in US gallons per minute Suction lift in feet						Max pump boost pressure (psi)
		0	5	10	15	20	25	
2T3K(S)C	20	16.5	16.0	15.0	14.0	13.0	12.5	52
	30	12.5	12.0	11.0	10.0	9.0	8.0	
	40	8.0	7.0	6.0	4.5	3.0	1.5	
2T4K(S)C	30	15.5	15.0	14.5	13.7	13.0	12.5	71
	40	12.5	12.0	11.2	10.5	9.7	9.0	
	50	9.2	8.5	7.5	6.5	5.7	4.7	
	60	5.2	4.2	3.2	2.0	1.0	-	
2T5K(S)C	40	14.7	14.2	13.7	13.2	12.7	12.2	88
	50	12.2	11.7	11.2	10.7	10.2	9.5	
	60	9.7	9.0	8.5	7.7	7.0	6.5	
	70	6.7	6.0	5.2	4.5	3.7	3.0	
2T6K(S)C	50	14.0	13.5	13.0	12.5	12.0	11.5	102
	60	11.7	11.2	10.7	10.2	9.7	9.2	
	70	9.5	9.0	8.5	8.0	7.5	7.0	
	80	7.0	6.5	6.0	5.2	4.7	4.0	
	90	4.2	3.5	3.0	2.2	1.5	0.5	
4T2K(S)C	10	29.5	27.0	25.5	24.0	23.0	21.5	35
	20	22.0	20.5	18.5	16.5	13.0	9.0	
4T3K(S)C	20	29.5	28.0	26.5	25.0	23.5	22.0	52
	30	22.5	21.0	19.0	17.0	15.0	13.0	
	40	13.0	12.0	9.5	7.0	4.5	1.5	
4T4K(S)C	30	29.0	27.5	26.5	25.5	24.0	22.5	71
	40	23.5	22.0	20.5	19.0	17.5	16.0	
	50	17.0	15.5	13.5	12.0	10.5	8.5	
	60	9.5	7.5	5.5	3.2	2.5	-	
	70	17.0	16.0	15.0	13.5	11.0	9.0	
4T5K(S)C	40	31.0	30.0	29.0	28.0	27.0	26.0	91
	50	26.0	25.0	24.0	23.0	22.0	21.0	
	60	22.0	21.0	20.0	19.0	18.0	17.0	
	70	17.0	16.0	15.0	13.5	11.0	9.0	

## V. Wiring Diagram for Auto Pressure Control

### WARNING:

Risk of Electrical Shock - This pump is supplied with a grounding conductor and grounding-type attachment plug. To reduce the risk of electric shock, be certain that it is connected only to a properly grounded, grounding-type receptacle".



This mark located outside the connection box is a warning for an electrical hazard.

Before operation, please check if the voltage is correct and be sure if the circuit breaker and grounding connectors are all connected in accordance with local regulations.

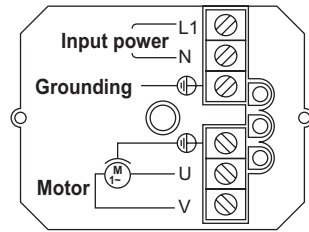

## VI. Dimensions: (in.)

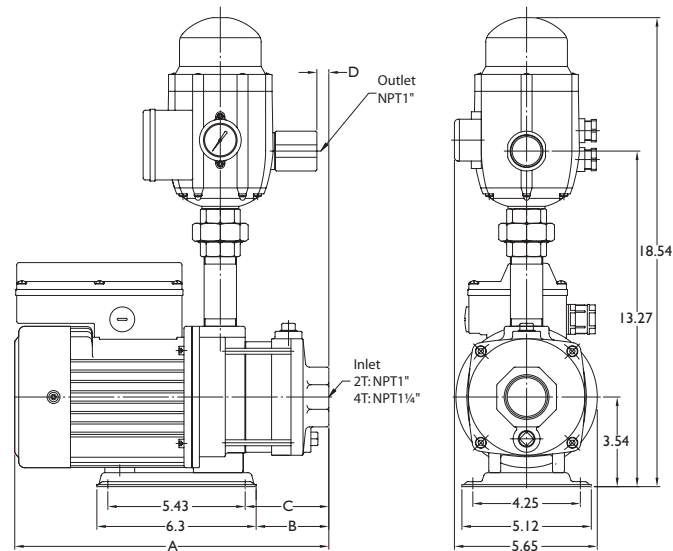

Model	Dimensions ( in. )			
	A	B	C	D
TPH2T3K(S)C	12.72	3.19	3.62	0.79
TPH2T4K(S)C	13.43	3.90	4.33	1.50
TPH2T5K(S)C	15.71	4.61	5.04	2.20
TPH2T6K(S)C	16.42	5.31	5.75	2.91
TPH4T2K(S)C	12.36	2.83	3.27	0.44
TPH4T3K(S)C	15.00	3.90	4.33	1.50
TPH4T4K(S)C	16.06	4.96	5.39	2.56
TPH4T5K(S)C	17.13	6.02	6.46	3.62

## VII. Troubleshooting



Before starting troubleshooting the pump, make sure that the power has been switched off and that it cannot be accidentally switched on.

Problem	Cause	Remedy
1. Pump doesn't stop:	a. Water leakage higher than 0.3gpm(1.2 lpm).	Check the system,the tap,etc, and fix the leak.
	b. Manual start switch (RESET) is blocked.	1. Press it for several times. 2. Consult your dealer if the problem persists.
	c. Failure of the electronic circuit board.	Replace it.
2. Pump doesn't start:	a. Not enough water supply, and the LED light (FAILURE) is illuminated.	Check the water supply and restart the pump by pressing the reset switch(RESET).
	b. Pump is blocked: LED (FAILURE) light is illuminated and by pressing the manual start switch (RESET), the LED (ON) is illuminated; but the pump doesn't work.	Consult your dealer.
	c. Failure of the electronic circuit board.	Switch off power supply, wait a few seconds and turn it on again. If the pump doesn't start immediately, it needs to replace the circuit board.
	d. No electrical supply.	Check the electrical supply. The LED light (POWER) should be illuminated.
	e. Pump pressure is too low and the LED light (FAILURE) is illuminated.	Check if the pump max pressure is at least 11psi(0.8kg/cm <sup>2</sup> ) higher than the starting pressure of the controller.
	f. Air Pocket in the system, and LED(FAILURE) is illuminated.	Check if all pipe joints are tightened. Reprime the pump to force the air out of the system.
3. The pump starts and stops frequently.	a. Leakage in the system.	Stop the leak.