



**WALRUS®**

*TPCK Series*

*Immersible Pump*

*Instruction Manual*



**ISO 9001 Certified**

---

Walrus America Inc

# EC Declaration of Conformity

Manufacturer:

Walrus Pump Co., Ltd.

Address:

No. 83 -14, Dapiantou, Sanjih Township, Taipei County 252,  
Taiwan

Declare that the machinery described:

Name : Water Pump

Model : TPCK Series

Conform to the following directive:

2006/42/EC—Machinery directive

2006/95/EC—Low voltage directive

2004/108/EC—EMC (Electromagnetic compatibility) directive

Refer to the following standards:

EN ISO 12100-1:2003

EN ISO 12100-2:2003

ISO14121-1:2007

EN60335-1:2001

EN 809:1998

EN60335-2-41:2001

EN61000-6-2

EN61000-6-3

R&D department manager: Kao Tien-chuan

Manager: *Kao Tien chuan*



Please read this instruction manual carefully before installing your new system as failures caused by incorrect installation and operation are not covered by the warranty.

## 1. Application

- 1.1. The TPCK series are multi-stage centrifugal pumps designed for industrial use, especially for machine tools.
- 1.2 The pump can not be used to transfer explosive liquids; such as gasoline, diesel oil or similar liquids. It is suitable to carry liquids such as water, coolant, low viscosity or other non-corrosive liquids.

## 2. Product Code

The standard range of pumps includes complete impeller in chamber combinations. Upon request, a special length can be supplied by fitting empty intermediate chambers instead of standard chambers with impellers. The pump nameplate indicates the number of chambers and impellers fitted to the pump.

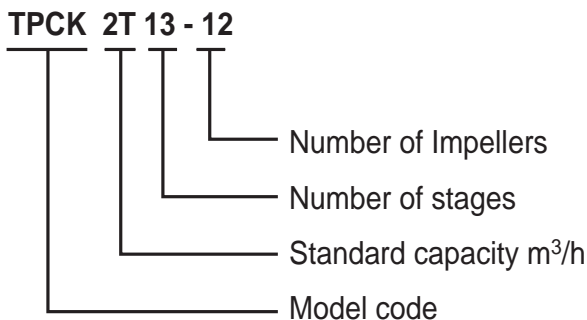

## 3. Operating Limits

1. Ambient temperature :Max. 122°F (50°C)
2. Liquid temperature range :32°F (0°C) to 194°F (90°C)
3. Flow: 4 GPM to 48 GMP
4. Head: 40ft to 850ft
5. Operating pressure :Max. 427 psi
6. Submerged depth :Min. 2.6"

## 4. Installation



The pump has hot surface on the motor. It must be installed so that persons cannot accidentally come into contact the hot surface.

### 4.1. Submerged Depth

To avoid dry running and damage the pump during operation, the minimum pump submerged depth is 65mm (2½") as shown in Fig 1. In addition, the bottom of the pump suction inlet must be at least 25 mm (1") above the bottom of the tank.

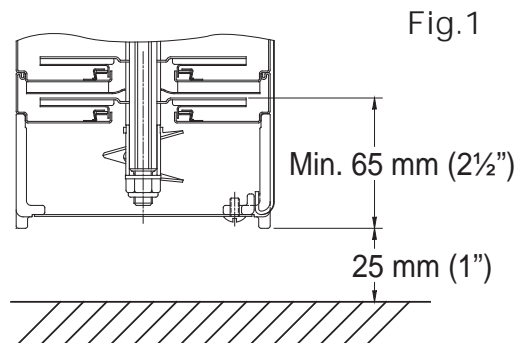

## 5. Electrical Connection



5.1 The electrical connection should be carried out in accordance with local regulations. Never make any connections unless the electricity supply has been switched off.



5.2. The electrical hazard warning mark is placed outside the connection box. Be careful.

5.3. Electrical data (voltage and frequency) are shown on the pump nameplate. Verify if these data match your electricity supply. A circuit breaker should be installed and the grounding be properly connected for your safety.

5.4. Make electrical connection in accordance with connecting diagram located inside the

connection box. The motor current must be within the rated amps range indicated on nameplate. Three phase motor requires a magnetic starter for safety.

- 5.5. Three phase motor must check rotating direction. The rotating direction indicated on the fan cover, is clockwise viewing from fan cover end. Interchanging any two leads with power off can reverse the pump rotation.

## 6. Start-up

- 6.1 Before starting the pump, make sure the following:
  - 6.1.1 All piping joints are completely tightened. Leakage in piping may cause the pump hydraulic loss.
  - 6.1.2 The pump is filled with liquid.
  - 6.1.3 The suction filter is not blocked by any foreign objects.
- 6.2 Start the pump as follows:
  - 6.2.1 Start the pump and check the direction of rotation.
  - 6.2.2 See the correct direction of rotation of the pump on the motor fan cover or on the coupling guard.

When seen from the top, the pump should rotate clockwise.

## 7. Operation and Maintenance



It is dangerous to operate the pump against a closed discharge outlet because it will cause extremely high liquid flow temperature and damage the pump in a few minutes.

### 7.1. Lubrication

The mechanical seal and shaft sleeves are lubricated by the pumped liquid.

### 7.2. Suction filter

Always keep suction filter clean and make sure it is not blocked by impurities.

### 7.3. Periodic checks

The following checks should be carried out periodically to ensure the normal operation.

7.3.1. The liquid level and operating pressure.

7.3.2. There are no leaks on piping and joints.

7.3.3. Check the tripping of the motor starter.

7.3.4. Check that all controls are functional.

7.4. The pump must not be used to transfer explosive liquids. In systems with hot liquids (over 140°F), extra caution should be exercised to prevent from personal injury.

7.5. The pump should not be used to transfer toxic or contaminated liquids. Please carefully follow all instructions in the manual as Walrus may refuse to accept the contaminated pump for servicing.

## 8. Sound pressure level

Motor [kW]	$\bar{L}_A$ dB(A)	
	50Hz	60Hz
2.2	< 70	< 70
3.0	< 70	< 70
4.0	< 70	< 70

9.  Please lift or move the pump by hoist as shown in Fig 3 below.

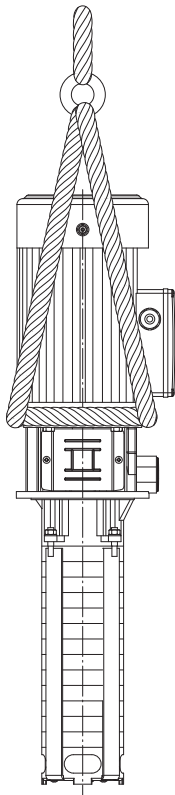

Fig.3

## 10. Trouble Shooting

Make sure electricity supply has been switched off before trouble shooting

Fault	Cause	Remedy
1. Motor does not run when started.	Supply failure.	Connect the electricity supply.
	Fuses are blown.	Replace fuses.
	Motor starter overload has tripped out.	Reactivate the motor protection.
	Thermal protection has tripped out.	Reactivate the thermal protection.
	Main contacts in motor starter are not making contact or the coil is faulty.	Replace contacts or magnetic coil.
	Control circuit is defective.	Repair the control circuit.
	Motor is defective.	Replace the motor.
2. Fuses Blow or motor starter overload trip.	One fuse/automatic circuit breaker is blown.	Cut in the fuse.
	Contacts in motor starter overload are faulty.	Replace motor starter contacts.
	Cable connection is loose or faulty.	Fasten or replace the cable connection.
	Motor winding is defective.	Replace the motor.
	Pump mechanically blocked.	Remove the mechanical blocking of the pump.
	Overload setting is too low.	Set the motor starter correctly.
	Low voltage at peak times	Check the electricity supply.
3. Pump runs but does not deliver water or the discharge flow is inconsistent.	Pump strainer partly blocked by impurities.	Clean the strainer.
	Liquid level in tank too low.	Increase the liquid level.
	Pump draws in air.	Check the suction conditions.
4. Noise.	Pump sucks in air.	Check the suction conditions.
	Pump does not rotate freely (frictional resistance) because of incorrect pump shaft position.	Adjust the pump shaft.

# Connecting parts drawing

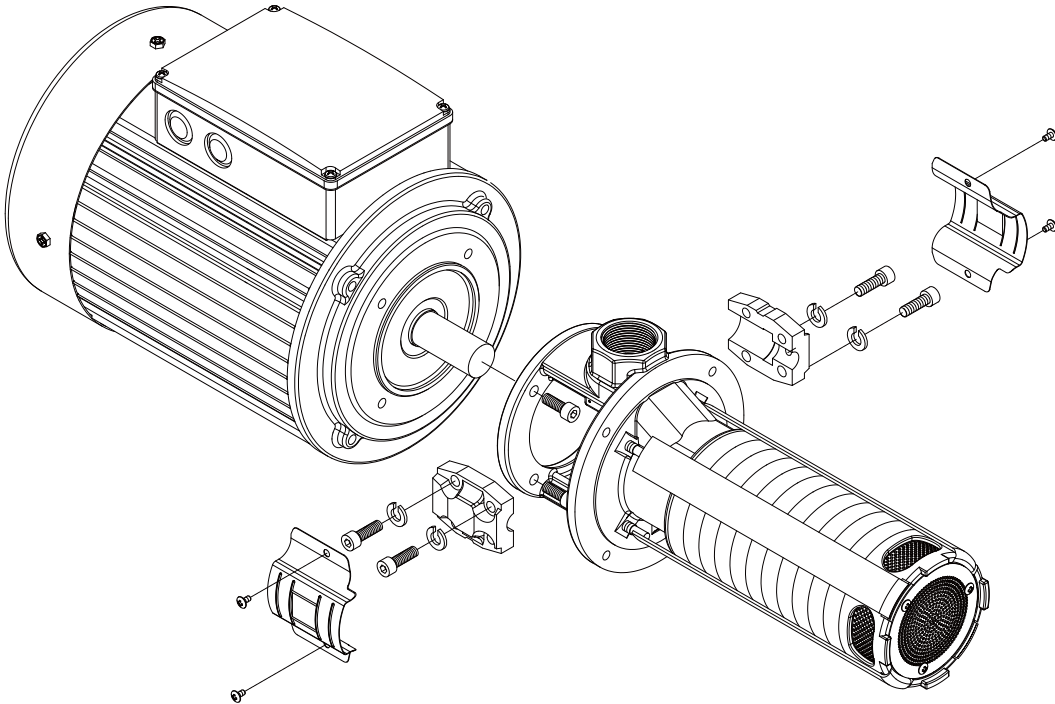

## Coupling adjustment

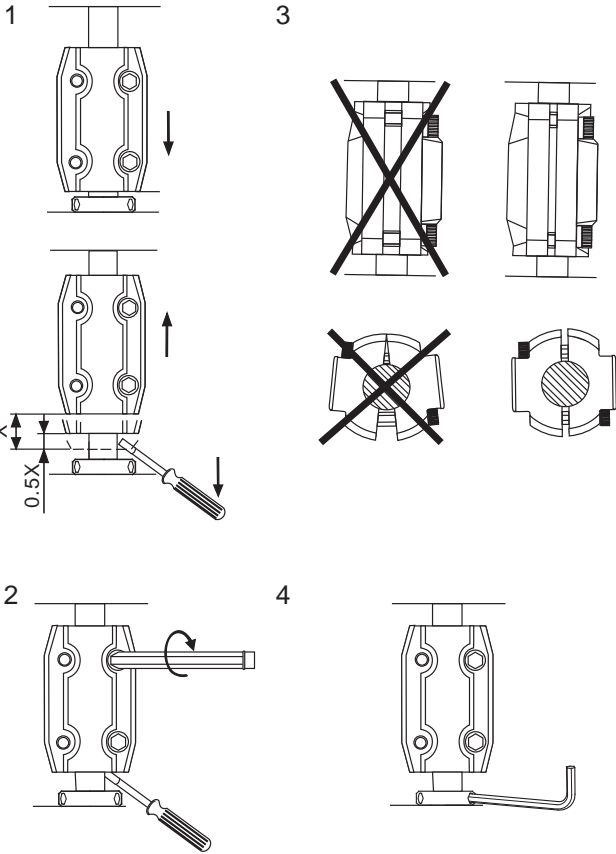
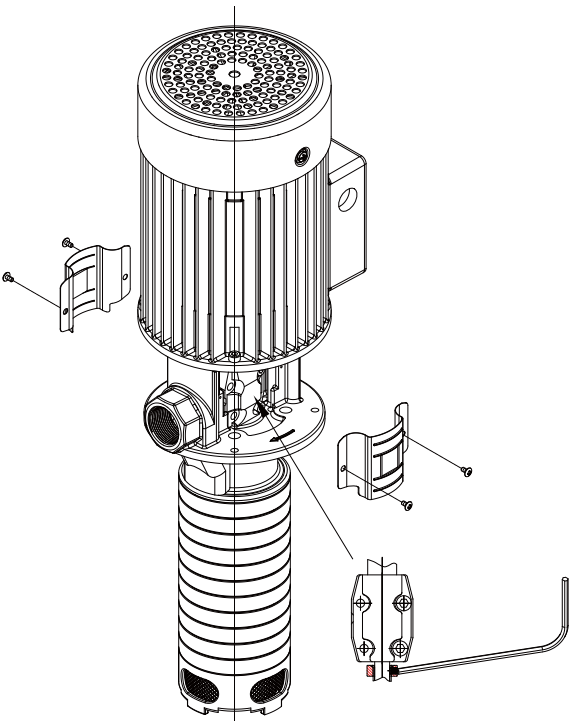

# Limited Warranty

Products manufactured by Walrus Pumps Co (Walrus) are warranted to the first user only to be free of defects in material and workmanship for a period of 12 months from date of installation, but no more than 24 months from date of shipment. Walrus' liability under this warranty shall be limited to repairing or replacing at our election, without charge, FOB Walrus' distribution center or authorized service agent. Walrus will not be liable for any cost of removal, installation, transportation or any other charges that may arise in connection with warranty claim.

The warranty period commences on the date of original purchase of the equipment. Proof of purchase and installation date, failure date, and supporting installation data must be provided when claiming repairs under warranty.

This warranty is subject to due compliance by the original purchaser with all directions and conditions set out in the installation and operating instructions. Failure to comply with these instructions, damage or breakdown caused by fair wear and tear, negligence, misuse, incorrect installation, inappropriate chemicals or additives in the water, inadequate protection against freezing, rain or other adverse weather conditions, corrosive or abrasive water, lightning or high voltage spikes or through unauthorized persons attempting repairs are not covered under warranty.

Walrus will not be liable for any incidental or consequential damages, losses, or expenses, arising from installation, use, or any other causes. There are no express or implied warranties, including merchantability or fitness for a particular purpose, which extend beyond those warranties described or referred to above.

Certain states do not permit the exclusion or limitation of incidental or consequential damages or the placing of limitations on the duration of an implied warranty, therefore, the limitations or exclusions herein may not apply. This warranty sets forth specific legal rights and obligations, however, additional rights may exist, which may vary from state to state.

Supersedes all previous publications



**WALRUS**®

Walrus America Inc

9808 Whithorn Drive, Houston, TX 77095

Web: [www.walrusamerica.com](http://www.walrusamerica.com)