

WALRUS®

TPAK Series

COOLANT PUMP

Instruction Manual



ISO 9001 Certified

Walrus America Inc

EC Declaration of Conformity

Manufacturer:

Walrus Pump Co., Ltd.

Address:

No. 83 -14, Dapiantou, Sanjih Township, Taipei County 252, Taiwan

Declare that the machinery described:

Name : Water Pump

Model : TPAK Series

Conform to the following directive:

2006/42/EC—Machinery directive

2006/95/EC—Low voltage directive

2004/108/EC—EMC (Electromagnetic compatibility) directive

Refer to the following standards:

EN ISO 12100-1:2003 EN ISO 12100-2:2003

ISO14121-1:2007:1996

EN60335-1:2001 EN 809:1998

EN60335-2-41:2001

EN61000-6-2:2005 EN61000-6-3

R&D department manager: Kao Tien-chuan

Kao Tien chuan



Please read this instruction manual carefully before installing your new system as failures caused by incorrect installation and operation are not covered by the warranty.

1. Application

The TPAK Series coolant pumps are designed for the circulation and spraying of cooling lubricants, especially for machine tools.

This series may use on all machine tools performing Turning, Milling, Drilling, Cutting, Slitting, Grinding etc. operation.

It is suitable to carry liquids such as water, coolant, light oil and other clean, non aggressive fluids.

2. Model Code

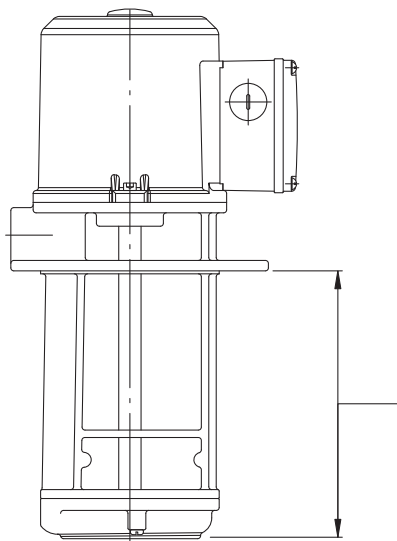

TPAK 1 - 18

Installation length

18 = 180 mm

25 = 250 mm

Output power

1 = 1/8 HP

2 = 1/4 HP

4 = 1/2 HP

8 = 1 HP

Model name

3. Operating Limits

Max. flow : 60 GPM

Max. head : 56 ft

Max. ambient temperature : +104°F

Max. liquid temperature range : +194°F

Max. operating pressure : 142 psi

4. Installation



The pump has hot surface on the motor. It must be installed so that persons cannot accidentally come into contact the hot surface.

4.1.Pump location

Note: The pumps can only be mounted in vertical position, see fig.1.

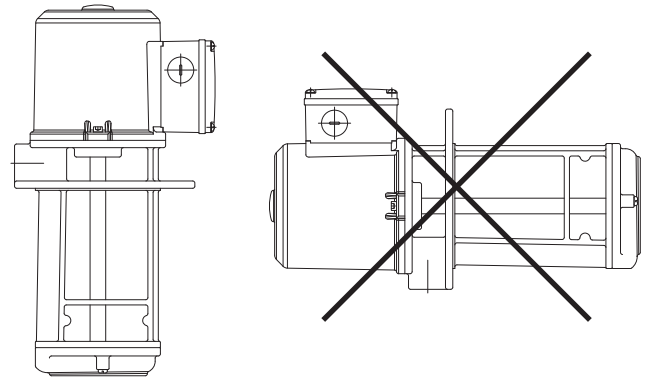
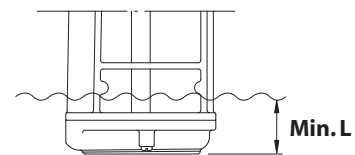

Fig.1

4.2.Minimum submerged depth : L (inch)



Model	TPAK 1	TPAK 2	TPAK 4	TPAK 8
L (in.)	1.57"	1.97"	2.36"	2.76"

4.3.Maximum liquid level

The maximum liquid level in the installation tank must be 0.8 inch below the top of the tank.

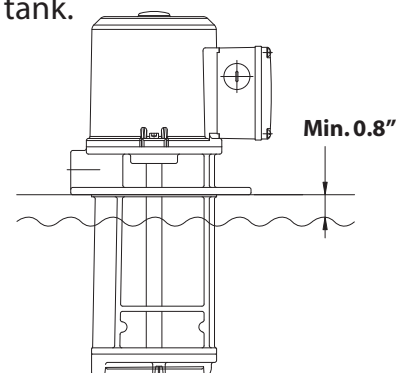

5. Electrical Connection



5.1 The electrical connection should be carried out in accordance with local regulations. Never make any connections unless the electricity supply has been switched off.



5.2. The electrical hazard warning mark is placed outside the connection box. Be careful.

5.3. Electrical data (voltage and frequency) are shown on the pump nameplate. Verify if these data match your electricity supply. A circuit breaker should be installed and the grounding be properly connected for your safety.

5.4. Make electrical connection in accordance with connecting diagram located inside the connection box. The motor current must be within the rated amps range indicated on nameplate. Three phase motor requires a magnetic starter for safety.

5.5. For three phase motors, look down from the fan cover the correct direction of rotation is rotate clockwise. if wrong rotation, you can reverse the direction of rotation by interchanging any two of the incoming supply wires.

5.6. Motors must be equipped with overload protector and open-phase protector to avoid motor damage.

6. Start-up

Before starting the pump, make sure the following:

6.1. For three phase motors, verify if the rotating direction is correct. It should be clockwise, look down from the motor fan cover.

6.2. All piping joints are completely tight. Leakage in piping may cause the pump hydraulic loss.

6.3. The pump is filled with liquid.

6.4. The suction filter is not blocked by any foreign objects.

7. Operation and Maintenance



It is dangerous to operate the pump against a closed discharge outlet because it will cause extremely high liquid flow temperature and damage the pump in a few minutes.

7.1. Periodic checks

The following checks should be carried out periodically to ensure the normal operation.

7.1.1. Check the liquid volume and operating pressure.

7.1.2. Check there are no leaks on piping joints.

7.1.3. Check the tripping of the motor starter.

7.1.4. Check that all controls are functioned normally.

7.2. The pump must not be used to transfer explosive liquids. In systems with hot liquids (over 140°F), extra caution should be exercised to prevent from personal injury.

7.3. The pump should not be used to transfer toxic or contaminated liquids. Please carefully follow all instructions in the manual as Walrus may refuse to accept the contaminated pump for servicing.

8. Sound pressure level

Motor	dB(A)
TPAK 1	<70
TPAK 2	<70
TPAK 4	<70
TPAK 8	<70

9. Wiring diagram

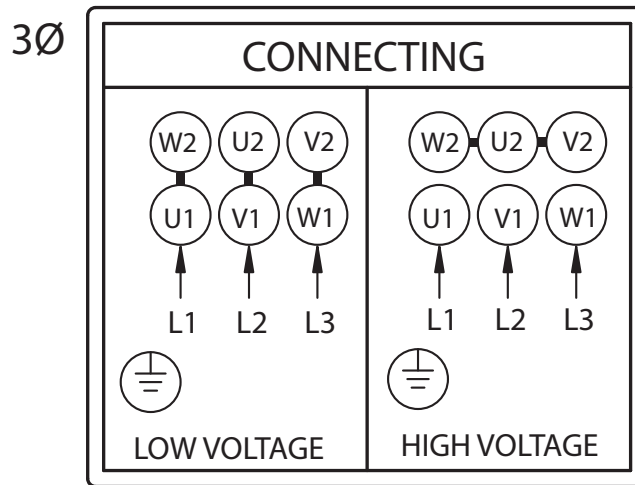

10. Fault Finding

Make sure electricity supply has been switched off before attempting to diagnose any fault

Fault	Cause
10.1 Motor does not start	a. No electricity supply
	b. Fuses are blown.
	c. Motor overheating relay tripped.
	d. Defective magnetic contactors.
	e. Control circuit malfunction.
10.2. Motor cut out during operation.	a. Fuses blown or breakers tripped.
	b. Overheating relay tripped.
	c. Control circuit malfunction.
	d. Pump locked up by foreign objects.
10.3. Pumped capacity is not constant.	a. Pump impeller blocked by impurities.
	b. Insufficient liquid level in the tank. (See Sec. 4.2)
10.4. Pump runs but gives no liquid.	a. Impellers damage.
	b. Liquid level is too low (See Sec. 4.2)
	c. Incorrect rotating direction.

11. Dimensions

TPAK 1 / TPAK 2

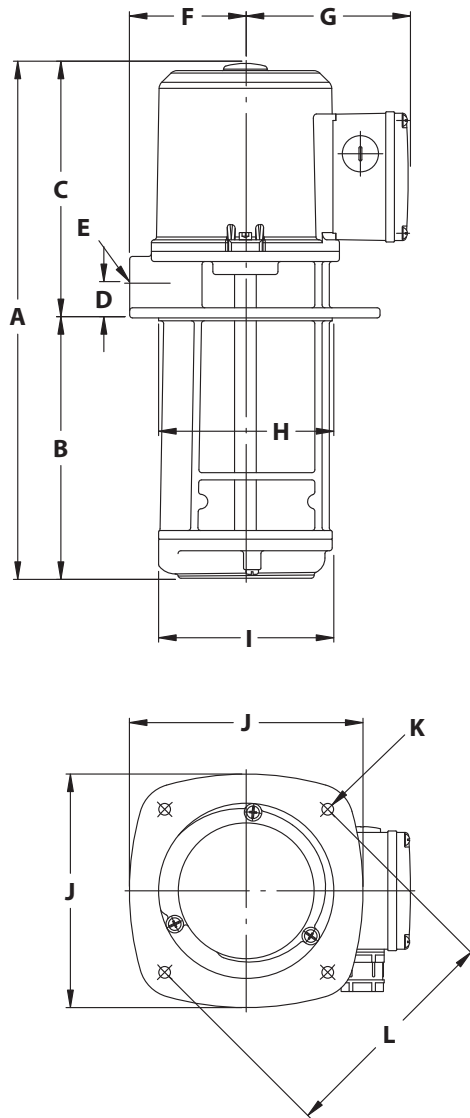

TPAK 4 / TPAK 8

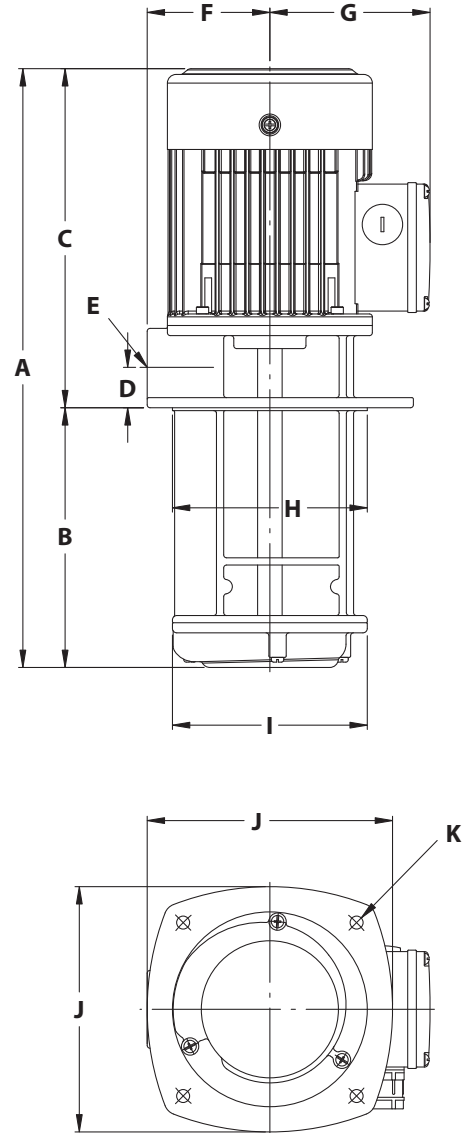

Model	DIMENSIONS: (inch)											Net Weight (lbs)
	A	B	C	D	E	F	G	H	I	J	K	
TPAK 1-18	13.39	7.09	6.30	0.63	NPT 3/8"	2.48	3.96	Ø3.54	Ø3.54	4.96	4xØ0.31 PCD5.04	12.1
TPAK 2-15	12.80	5.91	6.89	0.94	NPT 1/2"	3.15	4.43	Ø4.72	Ø4.72	6.30	4xØ0.31 PCD6.22	20.9
TPAK 2-18	13.98	7.09	6.89	0.94	NPT 1/2"	3.15	4.43	Ø4.72	Ø4.72	6.30	4xØ0.31 PCD6.22	22.0
TPAK 2-25	16.73	9.84	6.89	0.94	NPT 1/2"	3.15	4.43	Ø4.72	Ø4.72	6.30	4xØ0.31 PCD6.22	23.3
TPAK 4-15	15.16	5.91	9.25	1.10	NPT 3/4"	3.35	4.37	Ø5.31	Ø5.31	6.69	4xØ0.35 PCD6.69	24.7
TPAK 4-18	16.34	7.09	9.25	1.10	NPT 3/4"	3.35	4.37	Ø5.31	Ø5.31	6.69	4xØ0.35 PCD6.69	26.2
TPAK 4-25	19.09	9.84	9.25	1.10	NPT 3/4"	3.35	4.37	Ø5.31	Ø5.31	6.69	4xØ0.35 PCD6.69	28.0
TPAK 8-18	17.95	7.09	10.87	1.14	NPT 1"	3.74	4.37	Ø5.91	Ø5.91	7.48	4xØ0.35 PCD7.28	34.1
TPAK 8-25	20.71	9.84	10.87	1.14	NPT 1"	3.74	4.37	Ø5.91	Ø5.91	7.48	4xØ0.35 PCD7.28	37.7

12. SPECIFICATION

Model	Power (HP)	Phase (∅)	S.F.	Cycle (Hz)	Voltage (V)	Current (A)
TPAK 1-18	1/8	3∅	1.0	60	230 / 460	0.27 / 0.47
TPAK 2-15	1/4	3∅	1.6	60	230 / 460	1.24 / 0.67
TPAK 2-18	1/4	3∅	1.6	60	230 / 460	1.24 / 0.67
TPAK 2-25	1/4	3∅	1.6	60	230 / 460	1.24 / 0.67
TPAK 4-15	1/2	3∅	1.3	60	230 / 460	1.9 / 1.0
TPAK 4-18	1/2	3∅	1.3	60	230 / 460	1.9 / 1.0
TPAK 4-25	1/2	3∅	1.3	60	230 / 460	1.9 / 1.0
TPAK 8-18	1	3∅	1.5	60	230 / 460	4.0 / 2.2
TPAK 8-25	1	3∅	1.5	60	230 / 460	4.0 / 2.2

Limited Warranty

Products manufactured by Walrus Pumps Co (Walrus) are warranted to the first user only to be free of defects in material and workmanship for a period of 12 months from date of installation, but no more than 24 months from date of shipment. Walrus' liability under this warranty shall be limited to repairing or replacing at our election, without charge, FOB Walrus' distribution center or authorized service agent. Walrus will not be liable for any cost of removal, installation, transportation or any other charges that may arise in connection with warranty claim.

The warranty period commences on the date of original purchase of the equipment. Proof of purchase and installation date, failure date, and supporting installation data must be provided when claiming repairs under warranty.

This warranty is subject to due compliance by the original purchaser with all directions and conditions set out in the installation and operating instructions. Failure to comply with these instructions, damage or breakdown caused by fair wear and tear, negligence, misuse, incorrect installation, inappropriate chemicals or additives in the water, inadequate protection against freezing, rain or other adverse weather conditions, corrosive or abrasive water, lightning or high voltage spikes or through unauthorized persons attempting repairs are not covered under warranty.

Walrus will not be liable for any incidental or consequential damages, losses, or expenses, arising from installation, use, or any other causes. There are no express or implied warranties, including merchantability or fitness for a particular purpose, which extend beyond those warranties described or referred to above.

Certain states do not permit the exclusion or limitation of incidental or consequential damages or the placing of limitations on the duration of an implied warranty, therefore, the limitations or exclusions herein may not apply. This warranty sets forth specific legal rights and obligations, however, additional rights may exist, which may vary from state to state.

Supersedes all previous publications

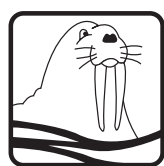

WALRUS®

Walrus America Inc

9808 Whithorn Drive, Houston, TX 77095

Web: www.walrusamerica.com

C099C015U000-00